



Raycap

Lightning & Surge Protection
for Wind Turbine Systems

Product Selection Guide



Table of Contents

Technologies for Wind Turbine Protection	3
Protective Device Recommendations	4
Class I Strikesorb Surge Protection Solutions	6
Class I SafeBloc for Wind Turbines	7
Class I DIN Rail Protection Solutions	8
Class II DIN Rail Protection Solutions	9
Class III DIN Rail DC Protection Solution	12
Signal & Data Protection Technologies	12
Lightning Protection Zones	15



Technologies for Wind Turbine Protection

Raycap offers the wind industry a variety of Surge Protective Device (SPD) technologies for the protection of wind turbines. Our solutions are ideally suited for these often remote and mission critical installations. The technologies included in the products we recommend include:

Strikesorb

Raycap's premium protection technology carries a 10 year warranty. This patented technology is uniquely equipped to safeguard against lightning surges, and has been engineered and tested for use in wind power applications. Strikesorb is maintenance free, due to its unparalleled ability to take multiple electrical surge events and not sacrifice itself. This performance against power surges makes Strikesorb the most reliable surge protection technology for the protection of the entire installation. Strikesorb complies with IEC/EN and UL 1449 4th Edition standards.

SafeBloc

SafeBloc products provide a good solution for all temporary overvoltages, surges and transients within the wind turbine. The SafeBloc modules offer good protection levels in an industry standard (compact) DIN rail form factor.

SafeTec

SafeTec delivers reliable solutions for temporary overvoltages, surges and transients and is suitable for many power protection applications within the turbine. The patented SafeTec technology is an open circuit mode in combination with current limiting technology. It prevents permanent disconnection during adverse temporary overvoltage (TOV) conditions. SafeTec is available in a (pluggable) DIN rail form factor. The products have lifetime indicators, are vibration and shock resistant, have a patented module locking mechanism, comply with IEC/EN and UL 1449 4th Edition standards, and have a 5 year warranty.

ProTec and ProTec ADV

The ProTec products offer very good electrical protection using a variety of surge protection technologies. The pluggable DIN rail designs include staged lifetime indicators, vibration and shock capability, a patented module locking mechanism and comply with IEC/EN and UL 1449 4th Edition standards. ProTec modules are suitable for many power protection applications within the turbine. ProTec comes with a 2 year warranty.

RayDat

RayDat products are the recommended solution for surge protection on the signal or data lines that run throughout the wind turbine. Technologies in this product group include transient voltage suppression (TVS) diodes and gas discharge tubes (GDT). The products are compliant with IEC/EN and UL 497B 4th Edition. RayDat products carry a 2 year warranty.



Protective Device Recommendations

Protected Area	Superior	Power Lines		DC & Data/Signals
		Advantaged	Basic	
1 Transformer	Strikesorb 80 Strikesorb 40 Strikesorb 30	SafeBloc B ProTec T1	SafeBloc B ProTec T1	
2 Mains Entrance and Converter	Strikesorb 80 Strikesorb 40 Strikesorb 30	SafeBloc B ProTec T1 ProTec T2-ADV SafeTec T2	SafeBloc B ProTec T1 ProTec T2	
3 Control Cabinet in the Tower Base	Strikesorb 30	ProTec T2-ADV SafeTec T2	ProTec T2	ProTec DMDR RayDat SBH/SLH RayDat NET 6 POE
4 Generator	Strikesorb 40	ProTec T1	ProTec T1	
5 Control Cabinet in the Nacelle	Strikesorb 30	ProTec T2-ADV SafeTec T2	ProTec T2	ProTec DMDR RayDat SBH/SLH RayDat NET 6 POE
6 Aviation Lights	Strikesorb 30	ProTec T2-ADV SafeTec T2	ProTec T2	
7 Environmental Measurement Systems				ProTec DMDR RayDat SBH/SLH
8 Pitch Control & Anti-/De-icing	Strikesorb 30	ProTec T2-ADV SafeTec T2	ProTec T2	RayDat SBH/SLH
9 Condition Monitoring				RayDat NET 6 POE

Protective Devices for Wind Power Systems

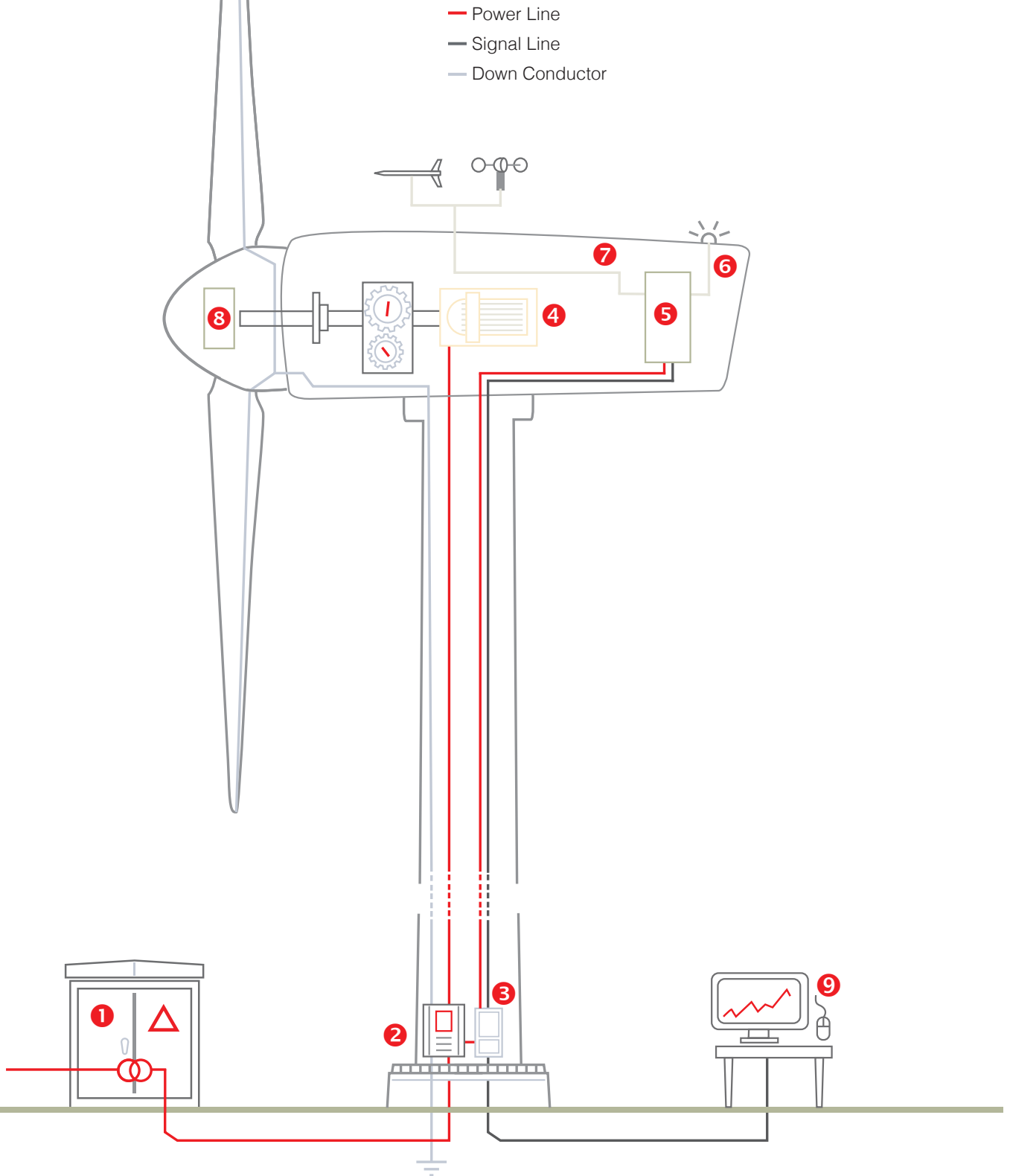

Surge Protection Solutions for Wind Turbine Systems

Strikesorb® 80

Class I



IEC/EN/UL Category: Class I / Type 1 / Type 2 CA
 Protective Elements: High Energy MOV
 Surge Ratings $I_{imp} = 25 \text{ kA}$ (10/350 μs)
 $I_{max} = 200 \text{ kA}$ (8/20 μs)
 Compliance: UL 1449 4th Edition
 IEC 61643-11: 2011
 EN 61643-11:2012
 IEEE C62.11: 2012
 IEEE C62.41.2: 2002
 IEEE C62.45: 2002



Strikesorb 80		80-D	80-F
Electrical			
Maximum Continuous Operating Voltage (AC)	U_c	480V	750V*
Nominal Discharge Current per UL 1449 4th Edition (8/20 μs)	I_n	20 kA	20 kA
Maximum Surge Current Capacity (8/20 μs)	I_{max}	200 kA	200 kA
Impulse Discharge Current (10/350 μs)	I_{imp}	25 kA	25 kA
Voltage Protection Level	U_p	1600V	2400V
Long Duration Surge Performance 1kA square waveform 2msec		250 hits	250 hits
TOV withstand 5s	U_T	716V	1143V

Order Information	
Strikesorb 80	Contact: info@raycap.com
*690V per IEC 61643-11	

Surge Protection Solutions for Wind Turbine Systems

Strikesorb 40

Class I



IEC/EN/UL Category: Class I / Type 1 / Type 2 CA
 Protective Elements: High Energy MOV
 Surge Ratings $I_{imp} = 12.5 \text{ kA}$ (10/350 μs)
 $I_{max} = 140 \text{ kA}$ (8/20 μs)
 Compliance: UL 1449 4th Edition
 IEC 61643-11: 2011
 EN 61643-11:2012
 IEEE C62.11: 2012
 IEEE C62.41.2: 2002
 IEEE C62.45: 2002



Strikesorb 40		40-B	40-D	40-F	40-G
Electrical					
Maximum Continuous Operating Voltage (AC)	U_c	300V	480V	750V*	1200V
Nominal Discharge Current per UL 1449 4th Edition (8/20 μs)	I_n	20 kA	20 kA	20 kA	20 kA
Maximum Surge Current Capacity (8/20 μs)	I_{max}	140 kA	140 kA	140 kA	140 kA
Impulse Discharge Current (10/350 μs)	I_{imp}	12.5 kA	12.5 kA	12.5 kA	12.5 kA
Voltage Protection Level	U_p	1200V	1800V	2800V	4400V
Long Duration Surge Performance 1kA square waveform 2msec		250 hits	250 hits	250 hits	250 hits
TOV withstand 5s	U_T	442V	762V	1143V	1905V

Order Information	
Strikesorb 40	Contact: info@raycap.com
*690V per IEC 61643-11	

Surge Protection Solutions for Wind Turbine Systems

Enhanced Strikesorb 30

Class I+II



IEC/EN/UL Category: Class I+II / Type 1+2 / Type 2 CA
 Protective Elements: High Energy MOV
 Surge Ratings $I_{imp} = 7.5 \text{ kA}$ (10/350 μs)
 $I_{max} = 60 \text{ kA}$ (8/20 μs)
 Compliance: UL 1449 4th Edition
 IEC 61643-11: 2011
 EN 61643-11:2012
 IEEE C62.11: 2012
 IEEE C62.41.2: 2002
 IEEE C62.45: 2002



Enhanced Strikesorb 30		30-B	30-D
Electrical			
Maximum Continuous Operating Voltage (AC)	U_c	275V	480V
Nominal Discharge Current per UL 1449 4th Edition (8/20 μs)	I_n	20 kA	20 kA
Maximum Surge Current Capacity (8/20 μs)	I_{max}	60 kA	60 kA
Impulse Discharge Current (10/350 μs)	I_{imp}	7.5 kA	7.5 kA
Voltage Protection Level	U_p	1200V	2200V
TOV withstand 5s	U_T	442V	762V
Order Information			
Strikesorb 30			Contact: info@raycap.com

Compact Single Pole SPD for Wind Turbine Systems

SafeBloc B(R) 25 (1+0) WT TCG

Class I+II



Location of Use: Main Distribution Boards
 Network Systems: TN-S, TN-C, TT (only L-N)
 Mode of Protection: L-PE, N-PE, L-PEN, L-N
 Surge Ratings $I_{imp} = 25 \text{ kA}$ (10/350 μs)
 $I_{max} = 80 \text{ kA}$ (8/20 μs)
 IEC/EN Category: Class I+II / Type 1, 2
 Protective Elements: High Energy MOV and GDT
 Safety: High TOV Immunity
 Leakage Current: No Leakage Current
 Housing: Compact Design
 Compliance: IEC 61643-11:2011
 EN 61643-11:2012



SafeBloc B(R) 25/750 (1+0) WT TCG		750
Electrical		
Maximum Continuous Operating Voltage (AC)	U_c	750V
Nominal Discharge Current (8/20 μs)	I_n	25 kA
Maximum Discharge Current (8/20 μs)	I_{max}	80 kA
Impulse Discharge Current (10/350 μs)	I_{imp}	25 kA
Voltage Protection Level	U_p	< 3.0 kV
Short-Circuit Current Rating (AC)	I_{SCCR}	50 kA
TOV withstand 5s	U_T	1000V
Order Information		
SafeBloc B 25/750 (1+0) WT TCG		54.0594
SafeBloc BR 25/750 (1+0) WT TCG (with remote contacts)		54.0595

Pluggable Multi-Pole SPD ProTec T1 2+0 Class I+II



Location of Use: Main Distribution Boards
 Network Systems: TN-S
 Mode of Protection: L-PE, N-PE
 Surge Ratings: I_{imp} = up to 12.5kA (10/350 μ s)
 I_{max} = 50kA (8/20 μ s)
 IEC/EN/UL Category: Class I+II / Type 1+2 / Type 1CA
 Protective Elements: High Energy MOV
 Housing: Pluggable Design
 Compliance: IEC 61643-11:2011
 EN 61643-11:2012
 UL 1449 4th Edition



ProTec T1-xxx-2+0(-R)

300

480

IEC Electrical

Maximum Continuous Operating Voltage (AC)	U_c	300V	480V
Nominal Discharge Current (8/20 μ s)	I_n	20kA	20kA
Maximum Discharge Current (8/20 μ s)	I_{max}	50kA	50kA
Impulse Discharge Current (10/350 μ s)	I_{imp}	12.5kA	10kA
Voltage Protection Level	U_p	1500V	2100V
Back-Up Fuse (max)		315 A / 250 A gG	
Short-Circuit Current Rating (AC)	I_{SCCR}	25 kA / 50 kA	
TOV Withstand 5s	U_T	337V	581V

Order Information

Order Code	300	480
ProTec T1-xxx-2+0	59.0021	59.0025
ProTec T1-xxx-2+0-R (with remote contacts)	59.0022	59.0026

Pluggable Multi-Pole SPD ProTec T1 3+0 Class I+II



Location of Use: Main Distribution Boards
 Network Systems: TN-C
 Mode of Protection: L-PEN
 Surge Ratings: I_{imp} = up to 12.5kA (10/350 μ s)
 I_{max} = up to 50kA (8/20 μ s)
 IEC/EN/UL Category: Class I+II / Type 1+2 / Type 1CA
 Protective Elements: High Energy MOV
 Housing: Pluggable Design
 Compliance: IEC 61643-11:2011
 EN 61643-11:2012
 UL 1449 4th Edition



ProTec T1-xxx-3+0(-R)

300

480

750

IEC Electrical

Maximum Continuous Operating Voltage (AC)	U_c	300V	480V	750V
Nominal Discharge Current (8/20 μ s)	I_n	20kA	20kA	20kA
Maximum Discharge Current (8/20 μ s)	I_{max}	50kA	50kA	35kA
Impulse Discharge Current (10/350 μ s)	I_{imp}	12.5kA	10kA	5kA
Voltage Protection Level	U_p	1500V	2100V	3200V
Back-Up Fuse (max)		315 A / 250 A gG		250 A gG
Short-Circuit Current Rating (AC)	I_{SCCR}	25 kA / 50 kA		50kA
TOV Withstand 5s	U_T	337V	581V	871V

Order Information

Order Code	300	480	750
ProTec T1-xxx-3+0	59.0031	59.0035	59.0037
ProTec T1-xxx-3+0-R (with remote contacts)	59.0032	59.0036	59.0038

Pluggable Multi-Pole SPD **SafeTec T2 3+0** Class II



Location of Use: Sub-distribution Boards
 Network Systems: TN-C
 Mode of Protection: L-PEN
 Surge Ratings: I_{max} = up to 50 kA (8/20 μ s)
 IEC/EN/UL Category: Class II / Type 2 / Type 1CA
 Protective Elements: High Energy MOV and GDT
 Safety: Patented Current Limiting Technology
 Housing: Pluggable Design
 Compliance: IEC 61643-11:2011
 EN 61643-11:2012
 UL 1449 4th Edition



SafeTec T2-xxx-3+0(-R)		300	480	750
IEC Electrical				
Maximum Continuous Operating Voltage (AC)	U_c	300 V	480 V	750 V
Nominal Discharge Current (8/20 μ s)	I_n	20 kA	20 kA	20 kA
Maximum Discharge Current (8/20 μ s)	I_{max}	50 kA	50 kA	35 kA
Voltage Protection Level	U_p	1650 V	2300 V	3500 V
Back-Up Fuse (max)		315 A / 250 A gG		
Short-Circuit Current Rating (AC)	I_{SCCR}	25 kA / 50 kA		
TOV Withstand 120min	U_T	442 V	762 V	1200 V
Order Information				
Order Code		300	480	750
SafeTec T2-xxx-3+0		59.0164	59.0168	59.0172
SafeTec T2-xxx-3+0-R (with remote contacts)		59.0165	59.0169	59.0173

Pluggable Multi-Pole SPD **ProTec T2 3+0** Class II



Location of Use: Sub-Distribution Boards
 Network Systems: TN-C
 Mode of Protection: L-PEN
 Surge Ratings: I_{max} = up to 50 kA (8/20 μ s)
 IEC/EN/UL Category: Class II / Type 2 / Type 1CA
 Protective Elements: High Energy MOV
 Housing: Pluggable Design
 Compliance: IEC 61643-11:2011
 EN 61643-11:2012
 UL 1449 4th Edition



ProTec T2-xxx-3+0(-R)		300	480	750
IEC Electrical				
Maximum Continuous Operating Voltage (AC)	U_c	300 V	480 V	750 V
Nominal Discharge Current (8/20 μ s)	I_n	20 kA	20 kA	20 kA
Maximum Discharge Current (8/20 μ s)	I_{max}	50 kA	50 kA	35 kA
Voltage Protection Level	U_p	1500 V	2300 V	3400 V
Back-Up Fuse (max)		315 A / 250 A gG		
Short-Circuit Current Rating (AC)	I_{SCCR}	25 kA / 50 kA		
TOV Withstand 5s	U_T	337 V	581 V	871 V
Order Information				
Order Code		300	480	750
ProTec T2-xxx-3+0		59.0093	59.0097	59.0099
ProTec T2-xxx-3+0-R (with remote contacts)		59.0094	59.0098	59.0100

Pluggable Multi-Pole SPD ProTec T2-ADV 3+0 Class II



Location of Use: Sub-Distribution Boards
 Network Systems: TN-C
 Mode of Protection: L-PEN
 Surge Ratings: $I_{max} = 50 \text{ kA}$ (8/20 μs)
 IEC/EN/UL Category: Class II / Type 2 / Type 1CA
 Protective Elements: High Energy MOV
 Housing: Pluggable Design
 Compliance: IEC 61643-11:2011
 EN 61643-11:2012
 UL 1449 4th Edition



ProTec T2-ADV-xxx-3+0(-R)		300	480
IEC Electrical			
Maximum Continuous Operating Voltage (AC)	U_c	300V	480V
Nominal Discharge Current (8/20 μs)	I_n	20kA	20kA
Maximum Discharge Current (8/20 μs)	I_{max}	50kA	50kA
Voltage Protection Level	U_p	1300V	2000V
Back-Up Fuse (max)		160A gG	
Short-Circuit Current Rating (AC)	I_{SCCR}	50kA	
TOV Withstand 5s	U_T	337V	581V
Order Information			
Order Code		300	480
ProTec T2-ADV-xxx-3+0		59.0230	59.0234
ProTec T2-ADV-xxx-3+0-R (with remote contacts)		59.0231	59.0235

Pluggable Multi-Pole SPD SafeTec T2 2+0 Class II



Location of Use: Sub-distribution Boards
 Network Systems: TN-S
 Mode of Protection: L-N, N-PE
 Surge Ratings: $I_{max} = 50 \text{ kA}$ (8/20 μs)
 IEC/EN/UL Category: Class II / Type 2 / Type 1CA
 Protective Elements: High Energy MOV and GDT
 Safety: Patented Current Limiting Technology
 Housing: Pluggable Design
 Compliance: IEC 61643-11:2011
 EN 61643-11:2012
 UL 1449 4th Edition



SafeTec T2-xxx-2+0(-R)		75	300	480
IEC Electrical				
Maximum Continuous Operating Voltage (AC)	U_c	75V	300V	480V
Nominal Discharge Current (8/20 μs)	I_n	20kA	20kA	20kA
Maximum Discharge Current (8/20 μs)	I_{max}	50kA	50kA	50kA
Voltage Protection Level	U_p	800V	1650V	2300V
Back-Up Fuse (max)		315 A/250A gG		
Short-Circuit Current Rating (AC)	I_{SCCR}	25kA/50kA		
TOV Withstand 120min	U_T	150V	442V	762V
Order Information				
Order Code		75	300	480
SafeTec T2-xxx-2+0		59.0345	59.0150	59.0154
SafeTec T2-xxx-2+0-R (with remote contacts)		59.0346	59.0151	59.0155

Pluggable Multi-Pole SPD ProTec T2 2+0 Class II



Location of Use: Sub-Distribution Boards
 Network Systems: TN-S
 Mode of Protection: L-PE, N-PE
 Surge Ratings: $I_{max} = 50 \text{ kA}$ (8/20 μs)
 IEC/EN/UL Category: Class II / Type 2 / Type 1CA
 Protective Elements: High Energy MOV
 Housing: Pluggable Design
 Compliance: IEC 61643-11:2011
 EN 61643-11:2012
 UL 1449 4th Edition



ProTec T2-xxx-2+0(-R)		75	300	480
IEC Electrical				
Maximum Continuous Operating Voltage (AC)	U_c	75V	300V	480V
Nominal Discharge Current (8/20 μs)	I_n	20kA	20kA	20kA
Maximum Discharge Current (8/20 μs)	I_{max}	50kA	50kA	50kA
Voltage Protection Level	U_p	800V	1500V	2300V
Back-Up Fuse (max)		315 A / 250 A gG		
Short-Circuit Current Rating (AC)	I_{SCCR}	25 kA / 50 kA		
TOV Withstand 5s	U_T	114V	337V	581V
Order Information				
Order Code		75	300	480
ProTec T2-xxx-2+0		59.0343	59.0083	59.0087
ProTec T2-xxx-2+0-R (with remote contacts)		59.0344	59.0084	59.0088

Pluggable Multi-Pole SPD ProTec T2-ADV 2+0 Class II



Location of Use: Sub-Distribution Boards
 Network Systems: TN-S
 Mode of Protection: L-PE, N-PE
 Surge Ratings: $I_{max} = 50 \text{ kA}$ (8/20 μs)
 IEC/EN/UL Category: Class II / Type 2 / Type 1CA
 Protective Elements: High Energy MOV
 Housing: Pluggable Design
 Compliance: IEC 61643-11:2011
 EN 61643-11:2012
 UL 1449 4th Edition



ProTec T2-ADV-xxx-2+0(-R)		75	300	480
IEC Electrical				
Maximum Continuous Operating Voltage (AC)	U_c	75V	300V	480V
Nominal Discharge Current (8/20 μs)	I_n	20kA	20kA	20kA
Maximum Discharge Current (8/20 μs)	I_{max}	50kA	50kA	50kA
Voltage Protection Level	U_p	600V	1300V	2000V
Back-Up Fuse (max)		160A gG		
Short-Circuit Current Rating (AC)	I_{SCCR}	50kA		
TOV Withstand 5s	U_T	114V	337V	581V
Order Information				
Order Code		75	300	480
ProTec T2-ADV-xxx-2+0		59.0347	59.0222	59.0226
ProTec T2-ADV-xxx-2+0-R (with remote contacts)		59.0348	59.0223	59.0227

DC Modular Multi-pole SPD ProTec DMDR 20 Series Class III



Location of Use: Sub-distribution Boards
 Network Systems: TN-S
 Mode of Protection: L-PE, N-PE, L-N
 Surge Ratings: U_{oc}/I_{cw} = up to 6kV/3kA
 I_{max} = up to 4kA (8/20 μ s)
 IEC/EN Category: Class III / Type 3
 Protective Elements: High Energy MOV and GDT
 Housing: Modular Design
 Compliance: IEC 61643-11:2011
 EN 61643-11:2012



ProTec DMDR 20/xxx		24	48	60	120
Electrical					
Maximum Continuous Operating Voltage (AC/DC)	U_c	24V/34V	48V/60V	60V/75V	120V/150V
Open Circuit Voltage of the Combination Wave Generator (1.2/50 μ s)	U_{oc}	2.4kV	2.4kV	6kV	6kV
Short Circuit Current of the Combination Wave Generator (8/20 μ s)	I_{cw}	1.2kA	1.2kA	3kA	3kA
Maximum Discharge Current (8/20 μ s)	I_{max}	2kA	2kA	4kA	4kA
Voltage Protection Level	(L-N) U_p	< 250V	< 500V	< 600V	< 1100V
	(L-PE)/(N-PE)	< 700V	< 800V	< 850V	< 1200V
Short-Circuit Current Rating (AC)	I_{SCCR}	2kA	2kA	2kA	2kA
Order Information					
ProTec DMDR 20/xxx		510 783	510 833	510 834	510 835

SPD for Category 6 LAN Networks RayDat NET 6 POE D1 • C1 • C2 • C3



IEC/EN Category: D1, C1, C2, C3
 Protection: All 4 Pairs
 Voltages: 48V DC
 Maximum Operating Voltage: 50V
 Frequency Range: 250MHz, up to Cat 6, POE Compatible
 Surge Discharge Ratings: I_n : 10kA, I_{imp} : 1kA
 Enclosure: UTB In-line Patch, DIN Rail Mount
 Terminals: RJ45, Shielded
 Housing: Compact Design
 Compliance: IEC/EN 61643-21
 UL 497B 4th Edition



RayDat NET 6		48
Electrical		
Nominal Operating Voltage (DC)	U_n	48V
Maximum Continuous Operating Voltage (DC)	(Line-Line) U_c	50V
Rated Load Current at 25°C	I_L	1A
Nominal Discharge Current (8/20 μ s)	(Line-Line) I_n	150A
C2 Total Discharge Current (8/20 μ s)	(Lines-Ground) I_{max}	10kA
D1 Impulse Current (10/350 μ s)	I_{imp}	1kA
Voltage Protection Level at I_n	(Line-Line) U_p	150V
	(Line-Ground)	550V
Order Information		
RayDat NET 6		706 312

Modular SPD for Industrial Fieldbus Systems

RayDat SBH-3 Series

D1 • C1 • C2 • C3



IEC/EN Category: D1, C1, C2, C3
 Mode of Protection: Longitudinal, Transverse
 Coarse Protection: 3 Terminal GDT
 Frequency Range: 30MHz
 Surge Discharge Ratings: I_n : 10kA, I_{max} : 20kA, I_{imp} : 2.5kA
 Series Load Current: 1A
 Enclosure: DIN 43880 2/3TE, DIN Rail Mount
 Terminals: Stranded to 4 mm²
 Housing: Modular Design
 Compliance: IEC/EN 61643-21
 UL 497B 4th Edition



SBH-3 Series		5	12	30
Electrical				
Nominal Operating Voltage (DC)	U_n	5V	12V	30V
Maximum Continuous Operating Voltage (DC)	U_c	6V	15V	33V
Rated Load Current at 25°C	I_L	1A	1A	1A
C2 Nominal Discharge Current (8/20µs)	I_n	10kA	10kA	10kA
Maximum Discharge Current (8/20µs)	I_{max}	20kA	20kA	20kA
D1 Impulse Current (10/350µs)	I_{imp}	2.5kA	2.5kA	2.5kA
Residual Voltage at 5kA (8/20µs)	(Line-Line) U_{res}	<22V	<42V	<80V
Order Information				
SBH-3-xx		7082.86	7082.88	7082.90
SBH-3-xx Q (Quick Connect Terminals)		7085.21	7085.22	7085.23

Modular SPD for Two Pair

RayDat SLH-4 Series

D1 • C1 • C2 • C3

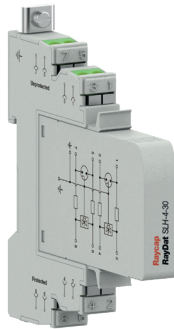

IEC/EN Category: D1, C1, C2, C3
 Mode of Protection: Longitudinal, Transverse
 Coarse Protection: 3 Terminal GDT
 Frequency Range: 30MHz
 Surge Discharge Ratings: I_n : 10kA, I_{max} : 20kA, I_{imp} : 5kA
 Series Load Current: 1A
 Enclosure: DIN 43880 2/3TE, DIN Rail Mount
 Terminals: Stranded to 4 mm²
 Housing: Modular Design
 Compliance: IEC/EN 61643-21
 UL 497B 4th Edition



SLH-4-30V		30
Electrical		
Nominal Operating Voltage (DC)	U_n	30V
Maximum Continuous Operating Voltage (DC)	U_c	33V
Rated Load Current at 25°C	I_L	1A
C2 Nominal Discharge Current (8/20µs)	I_n	10kA
Maximum Discharge Current (8/20µs)	I_{max}	20kA
D1 Impulse Current (10/350µs)	I_{imp}	5kA
Residual Voltage at 5kA (8/20µs)	U_{res}	<80V
Order Information		
SLH-4-30		7082.78
SLH-4 30VQ (Quick Connect Terminals)		7085.17



Lightning Protection Zones

Definition of Lightning Protection Zones (LPZ)

The following lightning protection zones are defined in an IEC 62305-4 standard, based on the expected damage which can be caused by atmospheric discharges.

Protection Zone	LPZ 0A	This zone is endangered by direct lightning strikes and includes the rotor, the tower, the nacelle, and the internal and external power cables.
Protection Zone	LPZ 0B	Within this zone there is a possibility of partial direct lightning strikes. The exposed parts are exterior sensors, warning lights, and radio antennas, etc. The shafts, bearings, generator, as well as the cooling and the hydraulic systems may also be affected by partial lightning surges.
Protection Zone	LPZ 1	This zone is in the interior of the wind power plant (in the nacelle and the tower) and is exposed to partial direct lightning strikes. At the transition between LPZs 0 and LPZs 1 the use of Class I surge arresters is recommended.
Protection Zone	LPZ 2	This zone is also in the interior of the wind power plant (in the nacelle and the tower) and is exposed to indirect lightning strikes. At the transition from LPZ 1 into LPZs 2 the use of Class 2 surge arresters is recommended.

Lightning Protection Level (LPL)

International standards specify four lightning protection levels (I to IV), i.e. the danger levels from lightning. Every LPL reflects the parameters for the maximum and minimum peak value of the lightning current.

Protection Level	PI	I	II	III	IV
Probability of Lightning Current > Minimum	P (%)	99	97	91	84
Minimum Peak Current	I (kA)	3	5	10	16
Maximum Peak Current	I (kA)	200	150	100	100
Rolling Sphere Radius	r (m)	20	30	45	60

Lightning current parameters and lightning ball radius (IEC 62305, "Lightning Protection", 2006).

The LPL can be determined using these standards. The following minimum LPL are the prerequisites for lightning protection:

- Offshore wind power plants: LPL I
- Wind power plants with a hub height > 60 m: LPL II
- Wind power plants with a hub height < 60 m: LPL III/IV



We reserve the right to introduce changes in performance, dimensions and materials in the course of technical progress. Copyright Raycap all rights reserved. No part of this work, nor of the information laid down herein and/or derivable here from and/or developed in connection with, may be reproduced or used in any form or by any means. Legal action will be taken against infringements. This publication replaces previous editions and the content herein is subject to change at any time without notice.

Raycap Worldwide Locations



Raycap Inc.
806 South Clearwater Loop
Post Falls, ID 83854
United States of America

Raycap | STEALTH
7555-A Palmetto Commerce
Parkway
North Charleston, SC 29420
United States of America

Raycap GmbH
Parkring 11
85748 Garching Munich
Germany

Raycap S.A.
Telou & Petroutsou 14
15124 Maroussi Athens
Greece

Raycap S.A. Manufacturing
Industrial Area of Drama
66100 Drama
Greece

Raycap d.o.o.
Pod hrasti 7
Poslovna cona Zeje pri Komendi
1218 Komenda
Slovenia

Raycap Cyprus Ltd.
46 Lefkosias Street
Industrial Area of Dali
2540 Nicosia
Cyprus

Raycap SAS
84 rue Charles Michels, Bldg. B
93200 Saint-Denis
France

Raycap Corporation SRL
4A, Johann Strauss, 4 Floor
Sector 2, 020312 Bucharest
Romania

Raycap (Suzhou) Co. Ltd.
Block B, Phase II
of New Sea Union
No. 58 Heshun Road
SIP, Suzhou 215122
Jiangsu Province
China



Raycap

raycap.com • info@raycap.com

