

# CYLINDRICAL

FUSE LINKS & FUSE HOLDERS

# CYLINDRICAL

FUSE LINKS & FUSE HOLDERS



04

**gG**  
CYL  
fuse links



07

**aM**  
CYL  
fuse links



10

**PMX**  
CYL  
fuse holders

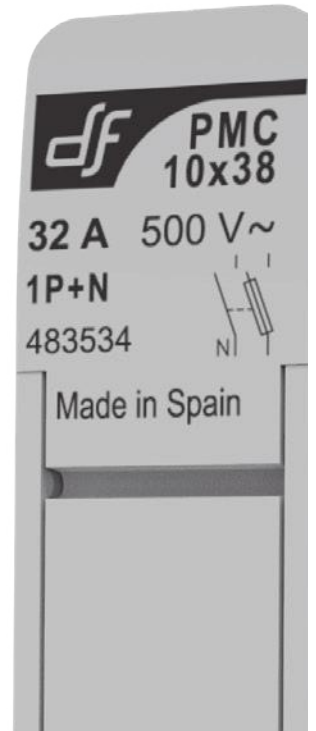

13

**PMC**  
CYL  
compact  
fuse holders

# CYLINDRICAL

FUSE LINKS & FUSE HOLDERS



14

**PMF**  
CYL  
fuse holders



15

**PMX-CC**  
CYL  
fuse holders



16

**CLIP  
CONTACT**  
CYL  
Ø10 fuse links



16

**PMB**  
CYL  
plug connection  
fuse holders

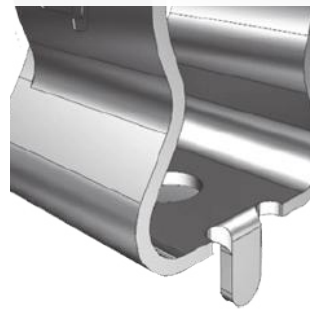



## gG CYLINDRICAL fuse links

Cylindrical fuse links gG class for use as general protection against overloads and short circuits, intended as protection of cables, power lines and equipment. Made of ceramic tube with high withstand to internal pressure and thermal shock, that allow a high breaking capacity in a reduced physical space.

The melting elements are specially designed in order to avoid aging and thus maintain unalterable the electrical characteristics. Contact caps are made of silver plated copper. Versions available with fusing indicator or with striker for use in fuse holders with microswitch.



U **400V**

BREAKING CAPACITY **20kA**

NEUTRAL LINK

In (A)	REFERENCE		PACKING Uni /BOX
	WITHOUT INDICATOR	WITH INDICATOR	
0,5	<b>420500</b>	—	10/100
1	<b>420501</b>	—	10/100
2	<b>420502</b>	<b>420602</b>	10/100
4	<b>420504</b>	<b>420604</b>	10/100
6	<b>420506</b>	<b>420606</b>	10/100
8	<b>420508</b>	<b>420608</b>	10/100
10	<b>420510</b>	<b>420610</b>	10/100
12	<b>420512</b>	<b>420612</b>	10/100
16	<b>420516</b>	<b>420616</b>	10/100
20	<b>420720</b>	<b>420820</b>	10/100
<b>430000</b>			10/100



U **500V**

BREAKING CAPACITY **120kA**

U **400V**

BREAKING CAPACITY **120kA**

NEUTRAL LINK

0,5	<b>420000</b>	—	10/100
1	<b>420001</b>	—	10/100
2	<b>420002</b>	<b>420102</b>	10/100
4	<b>420004</b>	<b>420104</b>	10/100
6	<b>420006</b>	<b>420106</b>	10/100
8	<b>420008</b>	<b>420108</b>	10/100
10	<b>420010</b>	<b>420110</b>	10/100
12	<b>420012</b>	<b>420112</b>	10/100
16	<b>420016</b>	<b>420116</b>	10/100
20	<b>420020</b>	<b>420120</b>	10/100
25	<b>420025</b>	<b>420125</b>	10/100
<b>420032</b>			10/100
<b>420032</b>			10/100
<b>420132</b>			10/100
<b>431000</b>			10/100



### STANDARDS

IEC 60269-1  
IEC 60269-2  
EN 60269-1  
EN 60269-2

### DIMENSIONS POWER DISSIPATION

PAG 17

### t-I | CUT-OFF | I<sub>2</sub>t CHARACTERISTICS

PAG 18

### DC APPLICATIONS FOR CYLINDRICAL FUSE LINKS

PAG 33

### COMPATIBLE PMX | PMC | PMF | PMB | CLIP CONTACT Ø10

PAG 10 <sup>PMX</sup>  
PAG 13 <sup>PMC</sup>

PAG 14 <sup>PMF</sup>  
PAG 16 <sup>PMB</sup> CLIP CONTACT Ø10

14x51

U **690V**  
BREAKING CAPACITY **80kA**

U **500V**  
BREAKING CAPACITY **120kA**

U **400V**  
BREAKING CAPACITY **120kA**

**NEUTRAL LINK**

In (A)	REFERENCE		PACKING Uni./BOX
	WITHOUT INDICATOR	WITH INDICATOR	
1	<b>421001</b>	-	10/50
2	<b>421002</b>	<b>421102</b>	10/50
4	<b>421004</b>	<b>421104</b>	10/50
6	<b>421006</b>	<b>421106</b>	10/50
8	<b>421008</b>	<b>421108</b>	10/50
10	<b>421010</b>	<b>421110</b>	10/50
12	<b>421012</b>	<b>421112</b>	10/50
16	<b>421016</b>	<b>421116</b>	10/50
20	<b>421020</b>	<b>421120</b>	10/50
25	<b>421025</b>	<b>421125</b>	10/50
32	<b>421032</b>	<b>421132</b>	10/50
40	<b>421040</b>	<b>421140</b>	10/50
50	<b>421050</b>	<b>421150</b>	10/50
<b>NEUTRAL LINK</b>		<b>432000</b>	10/50



22x58

U **690V**  
BREAKING CAPACITY **80kA**

U **500V**  
BREAKING CAPACITY **120kA**

**OVERRATING FUSES**  
U **400V**  
BREAKING CAPACITY **120kA**

**NEUTRAL LINK**

2	<b>422002</b>	<b>422102</b>	10/50
4	<b>422004</b>	<b>422104</b>	10/50
6	<b>422006</b>	<b>422106</b>	10/50
8	<b>422008</b>	<b>422108</b>	10/50
10	<b>422010</b>	<b>422110</b>	10/50
12	<b>422012</b>	<b>422112</b>	10/50
16	<b>422016</b>	<b>422116</b>	10/50
20	<b>422020</b>	<b>422120</b>	10/50
25	<b>422025</b>	<b>422125</b>	10/50
32	<b>422032</b>	<b>422132</b>	10/50
40	<b>422040</b>	<b>422140</b>	10/50
50	<b>422050</b>	<b>422150</b>	10/50
63	<b>422063</b>	<b>422163</b>	10/50
80	<b>422080</b>	<b>422180</b>	10/50
100	<b>422000</b>	<b>422100</b>	10/50
125	<b>422015</b>	<b>422115</b>	10/50
<b>NEUTRAL LINK</b>		<b>433000</b>	10/50



**STANDARDS**  
IEC 60269-1  
IEC 60269-2  
EN 60269-1  
EN 60269-2

**DIMENSIONS  
POWER DISSIPATION**  
PAG 17

**t-I | CUT-OFF | I<sub>2t</sub>  
CHARACTERISTICS**  
PAG 18

**DC APPLICATIONS FOR  
CYLINDRICAL FUSE LINKS**  
PAG 33

**COMPATIBLE  
PMX**  
PAG 10

14x51

U **500V**

BREAKING CAPACITY **120kA**

U **400V**

BREAKING CAPACITY **120kA**

**NEUTRAL LINK**

**In**  
(A)

**REFERENCE**

WITH  
STRIKER



**PACKING**

Uni /BOX

In (A)	REFERENCE	PACKING
2	<b>421202</b>	10/50
4	<b>421204</b>	10/50
6	<b>421206</b>	10/50
8	<b>421208</b>	10/50
10	<b>421210</b>	10/50
12	<b>421212</b>	10/50
16	<b>421216</b>	10/50
20	<b>421220</b>	10/50
25	<b>421225</b>	10/50
32	<b>421232</b>	10/50
40	<b>421240</b>	10/50
50	<b>421250</b>	10/50
	<b>432000</b>	10/50



22x58

U **690V**

BREAKING CAPACITY **80kA**

U **500V**

BREAKING CAPACITY **120kA**

**OVERRATING FUSES**

U **400V**

BREAKING CAPACITY **120kA**

**NEUTRAL LINK**

4  
6  
8  
10  
12  
16  
20  
25  
32  
40  
50  
63

**422204**  
**422206**  
**422208**  
**422210**  
**422212**  
**422216**  
**422220**  
**422225**  
**422232**  
**422240**  
**422250**  
**422263**

10/50  
10/50  
10/50  
10/50  
10/50  
10/50  
10/50  
10/50  
10/50  
10/50  
10/50  
10/50

80  
100  
125

**422280**  
**422200**  
**422215**

10/50  
10/50  
10/50

**433000**

10/50



**STANDARDS**

IEC 60269-1  
IEC 60269-2  
EN 60269-1  
EN 60269-2

**DIMENSIONS  
POWER DISSIPATION**

PAG 17

**t-I | CUT-OFF | I<sub>2</sub>t  
CHARACTERISTICS**

PAG 18

**DC APPLICATIONS FOR  
CYLINDRICAL FUSE LINKS**

PAG 33

**COMPATIBLE  
PMX**

PAG 10

## aM CYLINDRICAL fuse links

Cylindrical fuse links aM class are intended for short circuit protection in motors, transformer and other load with high inrush currents. Excellent protection of switchgear (contactor, thermal switch) due to the good current limiting capability and low  $I^2t$  values.

These fuse links must be associated to an overload device protection as a thermal switch. Made of ceramic tube with high withstand to internal pressure and thermal shock, that allow a high breaking capacity in a reduced physical space. The melting elements are silver plated in order to avoid the aging and thus keep unalterable the electric characteristics. Contacts caps are made of silver plated copper. Available versions with fusing indicator or with striker for use in fuse holders with microswitch.



8x32

U **400V**

BREAKING CAPACITY **20kA**

NEUTRAL LINK

In (A)	REFERENCE		PACKING Uni /BOX
	WITHOUT INDICATOR	WITH INDICATOR	
1	<b>411101</b>	<b>411201</b>	10/100
2	<b>411102</b>	<b>411202</b>	10/100
4	<b>411104</b>	<b>411204</b>	10/100
6	<b>411106</b>	<b>411206</b>	10/100
8	<b>411108</b>	—	10/100
10	<b>411110</b>	<b>411210</b>	10/100
NEUTRAL LINK		<b>430000</b>	10/100



10x38

U **500V**

BREAKING CAPACITY **120kA**

U **400V**

BREAKING CAPACITY **120kA**

NEUTRAL LINK

0,16	<b>440031</b>	—	10/100
0,25	<b>440033</b>	—	10/100
0,5	<b>440000</b>	—	10/100
1	<b>440001</b>	<b>440101</b>	10/100
2	<b>440002</b>	<b>440102</b>	10/100
4	<b>440004</b>	<b>440104</b>	10/100
6	<b>440006</b>	<b>440106</b>	10/100
8	<b>440008</b>	<b>440108</b>	10/100
10	<b>440010</b>	<b>440110</b>	10/100
12	<b>440012</b>	<b>440112</b>	10/100
16	<b>440016</b>	<b>440116</b>	10/100
NEUTRAL LINK		<b>431000</b>	10/100



### STANDARDS

IEC 60269-1  
IEC 60269-2  
EN 60269-1  
EN 60269-2

### DIMENSIONS POWER DISSIPATION

PAG 19

### t-I | CUT-OFF | I<sup>2</sup>t CHARACTERISTICS

PAG 20

### DC APPLICATIONS FOR CYLINDRICAL FUSE LINKS

PAG 33

### COMPATIBLE PMX | PMF

PAG 10 <sup>PMX</sup>  
PAG 14 <sup>PMF</sup>

# CYLINDRICAL

FUSE LINKS & FUSE HOLDERS

14x51

	U	In (A)	REFERENCE		PACKING Uni /BOX
			WITHOUT INDICATOR	WITH INDICATOR	
BREAKING CAPACITY 80kA	690V	0,25	<b>441031</b>	-	10/50
		0,5	<b>441000</b>	-	10/50
		1	<b>441001</b>	<b>441101</b>	10/50
		2	<b>441002</b>	<b>441102</b>	10/50
		4	<b>441004</b>	<b>441104</b>	10/50
		6	<b>441006</b>	<b>441106</b>	10/50
		8	<b>441008</b>	<b>441108</b>	10/50
		10	<b>441010</b>	<b>441110</b>	10/50
		12	<b>441012</b>	<b>441112</b>	10/50
		16	<b>441016</b>	<b>441116</b>	10/50
20	<b>441020</b>	<b>441120</b>	10/50		
25	<b>441025</b>	<b>441125</b>	10/50		
BREAKING CAPACITY 120kA	500V	32	<b>441032</b>	<b>441132</b>	10/50
		40	<b>441040</b>	<b>441140</b>	10/50
		45	<b>441045</b>	<b>441145</b>	10/50
BREAKING CAPACITY 120kA	400V	50	<b>441050</b>	<b>441150</b>	10/50
		<b>NEUTRAL LINK</b>		<b>432000</b>	10/50



22x58

BREAKING CAPACITY 80kA	690V	2	<b>442002</b>	<b>442102</b>	10/50
		4	<b>442004</b>	<b>442104</b>	10/50
		6	<b>442006</b>	<b>442106</b>	10/50
		8	<b>442008</b>	<b>442108</b>	10/50
		10	<b>442010</b>	<b>442110</b>	10/50
		12	<b>442012</b>	<b>442112</b>	10/50
		16	<b>442016</b>	<b>442116</b>	10/50
		20	<b>442020</b>	<b>442120</b>	10/50
		25	<b>442025</b>	<b>442125</b>	10/50
		32	<b>442032</b>	<b>442132</b>	10/50
BREAKING CAPACITY 120kA	500V	40	<b>442040</b>	<b>442140</b>	10/50
		50	<b>442050</b>	<b>442150</b>	10/50
		63	<b>442063</b>	<b>442163</b>	10/50
		80	<b>442080</b>	<b>442180</b>	10/50
OVERRATING FUSES BREAKING CAPACITY 120kA	400V	100	<b>442000</b>	<b>442100</b>	10/50
		125	<b>442015</b>	<b>442115</b>	10/50
<b>NEUTRAL LINK</b>			<b>433000</b>	10/50	



### STANDARDS

IEC 60269-1  
IEC 60269-2  
EN 60269-1  
EN 60269-2

### DIMENSIONS POWER DISSIPATION

PAG 19

### t-I | CUT-OFF | I<sub>2t</sub> CHARACTERISTICS

PAG 20

### DC APPLICATIONS FOR CYLINDRICAL FUSE LINKS

PAG 33

### COMPATIBLE PMX

PAG 10



14x51

U **500V**

BREAKING CAPACITY **120kA**

U **400V**

BREAKING CAPACITY **120kA**

**NEUTRAL LINK**

**In**  
(A)

**REFERENCE**

WITH  
STRIKER



**PACKING**

Uni /BOX

1	<b>441201</b>	10/50
2	<b>441202</b>	10/50
4	<b>441204</b>	10/50
6	<b>441206</b>	10/50
8	<b>441208</b>	10/50
10	<b>441210</b>	10/50
12	<b>441212</b>	10/50
16	<b>441216</b>	10/50
20	<b>441220</b>	10/50
25	<b>441225</b>	10/50
32	<b>441232</b>	10/50
40	<b>441240</b>	10/50
45	<b>441245</b>	10/50
50	<b>441250</b>	10/50
<b>NEUTRAL LINK</b>	<b>432000</b>	10/50



22x58

U **690V**

BREAKING CAPACITY **80kA**

U **500V**

BREAKING CAPACITY **120kA**

**OVERRATING FUSES**

U **400V**

BREAKING CAPACITY **120kA**

**NEUTRAL LINK**

2	<b>442202</b>	10/50
4	<b>442204</b>	10/50
6	<b>442206</b>	10/50
8	<b>442208</b>	10/50
10	<b>442210</b>	10/50
12	<b>442212</b>	10/50
16	<b>442216</b>	10/50
20	<b>442220</b>	10/50
25	<b>442225</b>	10/50
32	<b>442232</b>	10/50
40	<b>442240</b>	10/50
50	<b>442250</b>	10/50
63	<b>442263</b>	10/50
80	<b>422280</b>	10/50
100	<b>422200</b>	10/50
125	<b>442215</b>	10/50
<b>NEUTRAL LINK</b>	<b>433000</b>	10/50



**STANDARDS**

IEC 60269-1  
IEC 60269-2  
EN 60269-1  
EN 60269-2

**DIMENSIONS  
POWER DISSIPATION**

PAG 19

**t-I | CUT-OFF | I<sub>2</sub>t  
CHARACTERISTICS**

PAG 20

**DC APPLICATIONS FOR  
CYLINDRICAL FUSE LINKS**

PAG 33

**COMPATIBLE  
PMX**

PAG 10

# CYLINDRICAL

FUSE LINKS & FUSE HOLDERS



## PMX CYLINDRICAL fuse holders



- Available in an extended range of different versions with fuse indicator, with microswitch, 690V, 24 V DC, Microswitch FUSING + PRE-BREAKING + FUSE LINK DETECTION.
- Accessory available to lock the fuse holder by a padlock.
- IP20 Security accessory in terminal zones.
- For wires of section ≤10 mm<sup>2</sup>.
- All the versions with label holder for a good circuit identification.
- Compact design.
- Accessories for multiple poles assembly for fuse holders and microswitch.
- Ventilation zones optimized for a better heat dissipation.

- 2 position DIN Rail fixation.
- Made of a polymer high performance with a fusion temperature more than 300 °C. This provides a safety margin against a possible overheating of the fuse, and when it exceeds the rated power acceptance of the fuse holder.
- The PMX fuse holder can be fixed/unfixed on DIN rail with the same screwing tools that the installer uses for cable terminal fixing, regardless the screw driver head is in form of slot or PZZ.
- PMX Fuse holder is made of halogen free plastic, prepared for future restrictions on these substances.
- IEC (CB) tested.



U 400V AC/DC

In 25A

POLES	MODULES	REFERENCE		PACKING Uni /BOX
		WITHOUT INDICATOR	WITH INDICATOR	
I	1	<b>485001</b>	<b>485008</b>	12/180
I+N	2	<b>485003</b>	<b>485009</b>	6/90
2	2	<b>485004</b>	<b>485010</b>	6/90
3	3	<b>485005</b>	<b>485011</b>	4/60
3+N	4	<b>485006</b>	<b>485012</b>	3/45
4	4	<b>485007</b>	<b>485013</b>	3/45



U 690V AC  
750V DC

In 32A



I	1	<b>485101</b>	<b>485108</b>	12/180
N	1	<b>485102</b>	-	12/180
I+N	1	<b>485120</b>	-	12/180
I+N	2	<b>485103</b>	<b>485109</b>	6/90
2	2	<b>485104</b>	<b>485110</b>	6/90
3	3	<b>485105</b>	<b>485111</b>	4/60
3+N	3	<b>485121</b>	-	4/60
3+N	4	<b>485106</b>	<b>485112</b>	3/45
4	4	<b>485107</b>	<b>485113</b>	3/45
I	1,5	-	<b>485114</b>	12/180
2	3	-	<b>485116</b>	6/90



### ACCESSORIES

REFERENCE	DESCRIPTION	PACKING Uni /BOX
<b>480005</b>	PIN FOR MULTIPOLE ASSEMBLY	12/300
<b>485050</b>	HANDLE TIES FOR MULTIPOLE ASSEMBLY	12/300
<b>485051</b>	LOCK ACCESSORY	5
<b>485052</b>	SPECIAL IP20 PROTECTION ACCESSORY	24
<b>485053</b>	PHASE SEPARATOR ACCESSORY	12
<b>485054</b>	REPLACEMENT FUSING NEON INDICATOR 120/690V AC	6
<b>485055</b>	REPLACEMENT FUSING LED INDICATOR 24V DC	6
<b>485656</b>	SCREW PROTECTION ACCESSORY	20



### STANDARDS

IEC/EN 60269-1 UL 4248-1  
IEC/EN 60269-2  
GSA C22.2 4248-1

### TECHNICAL DATA

PAG 21

### MULTI-POLE ASSEMBLY

PAG 23

### DIMENSIONS

PAG 24

### ACCESSORIES

PAG 27

### COMPATIBLE gG | aM FUSE LINKS

PAG 04 <sup>gG</sup>  
PAG 07 <sup>aM</sup>

14x51

U **690V**

IN **50A**

STANDARDS

POLES	MODULES	REFERENCE		PACKING Uni /BOX
		WITHOUT INDICATOR	WITH INDICATOR	
1	1,5	<b>485201</b>	<b>485208</b>	6/90
	1,5	<b>485202</b>	-	6/90
1+N	3	<b>485203</b>	<b>485209</b>	3/45
	3	<b>485204</b>	<b>485210</b>	3/45
3	4,5	<b>485205</b>	<b>485211</b>	2/30
	6	<b>485206</b>	<b>485212</b>	1/18
3+N	6	<b>485207</b>	<b>485213</b>	1/18



U **24V DC**

IN **50A**

1	1,5	-	<b>485214</b>	6/90
1+N	3	-	<b>485215</b>	3/45
2	3	-	<b>485216</b>	3/45

**MICROSWITCH**

U **690V**

IN **50A**

STANDARDS

1	1,5	<b>485220</b>	<b>485226</b>	6/90
1+N	3	<b>485221</b>	<b>485227</b>	3/45
2	3	<b>485222</b>	<b>485228</b>	3/45
3	4,5	<b>485223</b>	<b>485229</b>	2/30
3+N	6	<b>485224</b>	<b>485230</b>	1/18
4	6	<b>485225</b>	<b>485231</b>	1/18



14x51

**ACCESSORIES**

\* to convert standard base on microswitch base only fusing and as microswitch PMX spare prebreaking-fusing-presence

REFERENCE	DESCRIPTION	PACKING Uni /BOX
<b>480005</b>	PIN FOR MULTIPOLE ASSEMBLY	12/300
<b>485356</b>	HANDLE TIES FOR MULTIPOLE ASSEMBLY	12/300
<b>485357</b>	HANDLE TIES FOR MICROSWITCH ASSEMBLY	12/300
<b>485258</b>	LOCK SUPPORT	5
<b>485259</b>	MICROSWITCH 1P *	5
<b>485260</b>	MICROSWITCH 3P *	2
<b>485261</b>	MICROSWITCH 3P (2M) *	2
<b>485262</b>	MICROSWITCH UNIPOLAR EXTENSION	5
<b>485263</b>	MICROSWITCH TRIPOLAR EXTENSION	2
<b>485264</b>	REPLACEMENT FUSING INDICATOR NEON 120/690 VAC	3
<b>485265</b>	REPLACEMENT FUSING INDICATOR LED 24 VDC	3
<b>485266</b>	SPECIAL PROTECTION IP20 ACCESSORY PMX-14	12
<b>485271</b>	SPECIAL CONNECTION M6 ACCESSORY	12
<b>485656</b>	SCREW PROTECTION ACCESSORY	20



**STANDARDS**

IEC/EN 60269-1 UL 4248-1  
IEC/EN 60269-2

**TECHNICAL DATA**

PAG 21

**MULTI-POLE ASSEMBLY**

PAG 23

**DIMENSIONS**

PAG 25

**ACCESSORIES**

PAG 27

**COMPATIBLE**  
gG | aM FUSE LINKS

PAG 04 <sup>gG</sup>  
PAG 07 <sup>aM</sup>

22x58

U	690V
IN	100A 125A
STANDARDS	
U	24V DC
IN	100A 125A

### MICROSWITCH

U	690V
IN	100A 125A
STANDARDS	

POLES	MODULES	REFERENCE		PACKING Uni /BOX
		WITHOUT INDICATOR	WITH INDICATOR	

690V	I	2	485301	485308	6/48	
	N	2	485302	-	6/48	
	I + N	4	485303	485309	3/24	
		2	4	485304	485310	3/24
		3	6	485305	485311	2/16
3 + N	8	485306	485312	1/8		
	4	8	485307	485313	1/8	
24V DC	1	2	-	485314	6/48	
	1+N	4	-	485315	3/24	
	2	4	-	485316	3/24	



690V	I	2	485320	485326	6/48
	I + N	4	485321	485327	3/24
	2	4	485322	485328	3/24
		3	6	485323	485329
	3+N	8	485324	485330	1/8
4	8	485325	485331	1/8	

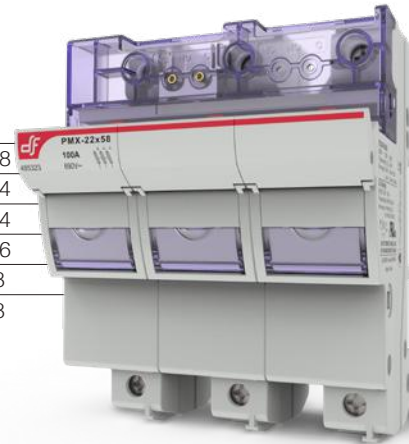

22x58

### ACCESSORIES

\* to convert standard base on microswitch base only fusing and as microswitch PMX spare prebreaking-fusing-presence

REFERENCE	DESCRIPTION	PACKING Uni /BOX
-----------	-------------	---------------------

480005	PIN FOR MULTIPOLE ASSEMBLY	12/300
485356	HANDLE TIES FOR MULTIPOLE ASSEMBLY	12/300
485357	HANDLE TIES FOR MICROSWITCH ASSEMBLY	12/300
485358	LOCK SUPPORT	5
485359	MICROSWITCH 1P *	5
485360	MICROSWITCH 3P *	2
485361	MICROSWITCH 3P (2M) *	2
485362	MICROSWITCH UNIPOLAR EXTENSION	5
485363	MICROSWITCH TRIPOLAR EXTENSION	2
485364	REPLACEMENT FUSING INDICATOR NEON 120/690 VAC	3
485365	REPLACEMENT FUSING INDICATOR LED 24 VDC	3
485366	SPECIAL PROTECTION IP20 ACCESSORIE PMX-22	12
485367	SPECIAL CONNECTION M8 ACCESSORY	12
485371	SCREW PROTECTION ACCESSORY	20

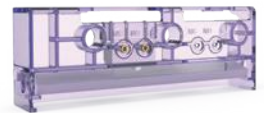

485360



485366

### STANDARDS

IEC/EN 60269-1 UL 4248-1  
IEC/EN 60269-2

### TECHNICAL DATA

PAG 21

### MULTI-POLE ASSEMBLY

PAG 23

### DIMENSIONS

PAG 26

### ACCESSORIES

PAG 27

### COMPATIBLE gG I aM FUSE LINKS

PAG 04 <sup>gG</sup>  
PAG 07 <sup>aM</sup>

### PMC CYLINDRICAL fuse holders

Compact fuse holders for industrial cylindrical fuse links. Very low dimensions. For mounting on DIN/EN rail. Single phase models or single phase + neutral in only one module. Multi-pole units can be made with connection accessories.

PMC fuse holders are made with self-extinguishable materials and have silver plated copper contacts.



**PATENTED DESIGN**

8x32

U **400V**  
In **25A**

POLES	MODULES	REFERENCE	PACKING Uni /BOX
I	1	<b>483500</b>	12/336
N	1	<b>483502</b>	12/336
I + N	1	<b>483504</b>	12/336
I + N	2	<b>483506</b>	6/168
2	2	<b>483508</b>	6/168
3	3	<b>483510</b>	4/112
3 + N	3	<b>483512</b>	4/112
3 + N	4	<b>483514</b>	3/84
4	4	<b>483516</b>	3/84



10x38

U **500V**  
In **32A**

I	1	<b>483530</b>	12/336
N	1	<b>483502</b>	12/336
I + N	1	<b>483534</b>	12/336
I + N	2	<b>483536</b>	6/168
2	2	<b>483538</b>	6/168
3	3	<b>483540</b>	4/112
3 + N	3	<b>483542</b>	4/112
3 + N	4	<b>483544</b>	3/84
4	4	<b>483546</b>	3/84



8x32 10x38

#### ACCESSORIES

REFERENCE	DESCRIPTION	PACKING Uni /BOX
<b>480005</b>	PINS FOR MULTIPOLE ASSEMBLY	12/300
<b>483550</b>	PMC HANDLE TIES FOR MULTIPOLE ASSEMBLY	12/300
<b>483552</b>	PMC MULTIPOLE ASSEMBLY KIT	10/500



480005

#### STANDARDS

IEC/EN 60269-1  
IEC/EN 60269-2

#### TECHNICAL DATA

PAG 22

#### MULTI-POLE ASSEMBLY

PAG 23

#### DIMENSIONS

PAG 29

#### COMPATIBLE gG | aM FUSE LINKS

PAG 04<sup>gG</sup>  
PAG 07<sup>aM</sup>



### PMF CYLINDRICAL fuse holders

Modular fuse holders for industrial cylindrical fuse links. For mounting on DIN/EN rail. Single phase models, single-phase+neutral in only one module and multi-pole types. Available with fusing indicator or with microswitch for use with fuse links with striker (only fusing detection or fusing+pre-breaking+fuse link detection).

Multi-pole units can be made of connection accessories. PMF fuse holders are made of self-extinguishable materials and have silver plated copper contacts.



U	690V
In	32A
U	400V
In	32A

POLES	MODULES	REFERENCE		PACKING Uni /BOX
		WITHOUT INDICATOR	WITH INDICATOR	
I N	1	<b>480032</b>	-	12/192
	1	<b>480032 N</b>	-	12/192
I + N	2	<b>480132</b>	-	6/96
	2	<b>480232</b>	-	6/96
	3	<b>480332</b>	-	4/64
	3 + N	<b>480432</b>	-	3/48
4	4	<b>480532</b>	-	3/48
	4	<b>480532</b>	-	3/48
I + N	1	<b>480135</b>	<b>480335 I</b>	12/192
	3	<b>480335</b>	-	4/64



#### ACCESSORIES

REFERENCE	DESCRIPCION	PACKING Uni /BOX
<b>480005</b>	PIN FOR MULTIPOLE ASSEMBLY	12/300
<b>480006</b>	HANDLE TIES FOR MULTIPOLE ASSEMBLY	12/300



#### STANDARDS

IEC/EN 60269-1  
IEC/EN 60269-2

#### TECHNICAL DATA

PAG 22

#### MULTI-POLE ASSEMBLY

PAG 23

#### DIMENSIONS

PAG 30

#### COMPATIBLE gG | aM FUSE LINKS

PAG 04<sup>gG</sup>  
PAG 07<sup>aM</sup>

# CYLINDRICAL

FUSE LINKS & FUSE HOLDERS



## PMX CC CLASS CYLINDRICAL fuse holders

Modular fuse holders for cylindrical **CC class fuse links**. For mounting on DIN/EN rail. Single phase and multi-pole types. Available with fusing indicator. Multi-pole units can be made with connection accessories.

PMCC fuse holders are made with self-extinguishable materials and have silver plated copper contacts. UL approval.



U **600V**

In **30A**

STANDARDS

### POLES

### REFERENCE

### PACKING

WITHOUT  
INDICATOR

WITH  
INDICATOR

Uni /BOX

POLES	REFERENCE	PACKING
I	<b>485181</b>	12/180
II	<b>485184</b>	6/90
III	<b>485185</b>	4/60



### ACCESSORIES

### REFERENCE

### DESCRIPTION

### PACKING

Uni /BOX

REFERENCE	DESCRIPTION	PACKING
<b>480005</b>	PIN FOR MULTIPOLE ASSEMBLY	12/300
<b>485050</b>	HANDLE TIES FOR MULTIPOLE ASSEMBLY	12/300



480005



485050

### STANDARDS

IEC/EN 60269-1 UL 4248-1  
IEC/EN 60269-2 UL 4248-4  
CSA C22.2 4248-4

### TECHNICAL DATA

PAG 22

### MULTI-POLE ASSEMBLY

PAG 23

### DIMENSIONS

PAG 31

# CYLINDRICAL

FUSE LINKS & FUSE HOLDERS



## CLIP CONTACT CYLINDRICAL Ø10 fuse links

Clip contact for Ø10 cylindrical fuse links.  
Screw fixation and PCB versions. Manufactured in tinned bronze.  
All the materials are according to the European Directive RoHS (Restriction of the use of certain hazardous substances in electrical material).



FIXATION **SCREW**

U UP TO **1500V AC/DC**

In **25A**

**P<sub>d</sub> max**  
(W)

**REFERENCE**

**PACKING**  
Uni /BOX

4

**482001**

50/200



FIXATION **PCB**

U UP TO **1500V AC/DC**

In **25A**

4

**482002**

50/200



## PLUG CONNECTION CYLINDRICAL fuse holders

Suitable for use with cylindrical fuses size 10x38 according to IEC 60269 standard.  
Contacts of silver electrolytic copper. Zinc plated brass connector.



U **500V**

In **32A**

**POLES**

**MODULES**

**REFERENCE**

**PACKING**  
Uni /BOX

1

1

**490030**

20/100



### STANDARDS

IEC 60269-1  
IEC 60269-2  
EN 60269-1  
EN 60269-2

### TECHNICAL DATA

PAG 22

### DIMENSIONS

PAG 32 CLIP CONTACT Ø10

### COMPATIBLE gG FUSE LINKS

PAG 04



**gG** CYLINDRICAL fuse links



## DIMENSIONS

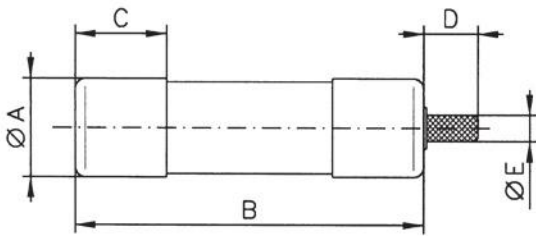

	A	B	C	D	E
<b>8x32</b>	8,5	31,5	6,3	-	-
<b>10x38</b>	10,3	38	8,5	-	-
<b>14x51</b>	14,3	51	11,5	8	3,7
<b>22x58</b>	22,2	58	15,5	8	3,7

## TECHNICAL DATA

	RATED VOLTAGE	RATED CURRENT	BREAKING CAPACITY
<b>8x32</b>	400V	0,5A...20A	20kA
<b>10x38</b>	500V 400V	0,5A...25A 32A	120kA 120kA
<b>14x51</b>	690V 500V 400V	1A...25A 32A   40A 50A	80kA 120kA 120kA
<b>22x58</b>	690V 500V 400V	2A...63A 80A   100A 125A	80kA 120kA 120kA

## POWER DISSIPATION

RATED CURRENT (A)	8x32 (W)	10x38 (W)	14x51 (W)	22x58 (W)
<b>0,5</b>	1,2	1,43	-	-
<b>1</b>	2,0	2,77	3,90	-
<b>2</b>	0,5	0,60	0,90	1,00
<b>4</b>	0,8	0,70	1,00	1,10
<b>6</b>	1,1	0,85	1,15	1,30
<b>8</b>	1,3	0,75	1,00	1,10
<b>10</b>	1,0	1,00	1,30	1,50
<b>12</b>	1,2	1,30	1,70	1,80
<b>16</b>	1,5	1,60	2,00	2,10
<b>20</b>	2,0	2,00	2,50	2,70
<b>25</b>	-	2,60	3,30	3,30
<b>32</b>	-	2,90	3,50	3,50
<b>40</b>	-	-	4,75	4,00
<b>50</b>	-	-	4,80	5,50
<b>63</b>	-	-	-	6,90
<b>80</b>	-	-	-	7,80
<b>100</b>	-	-	-	9,00
<b>125</b>	-	-	-	11,4

## t-I CHARACTERISTICS

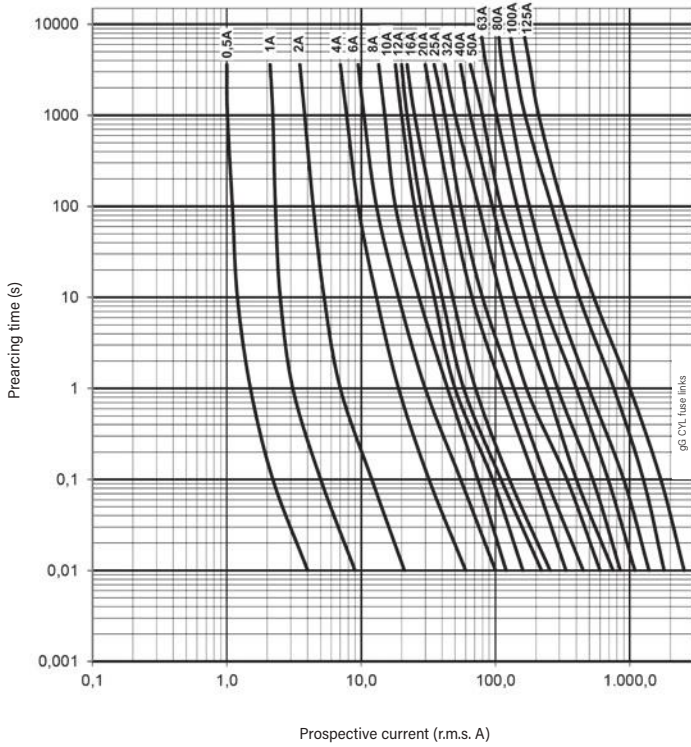

## CUT-OFF CHARACTERISTICS

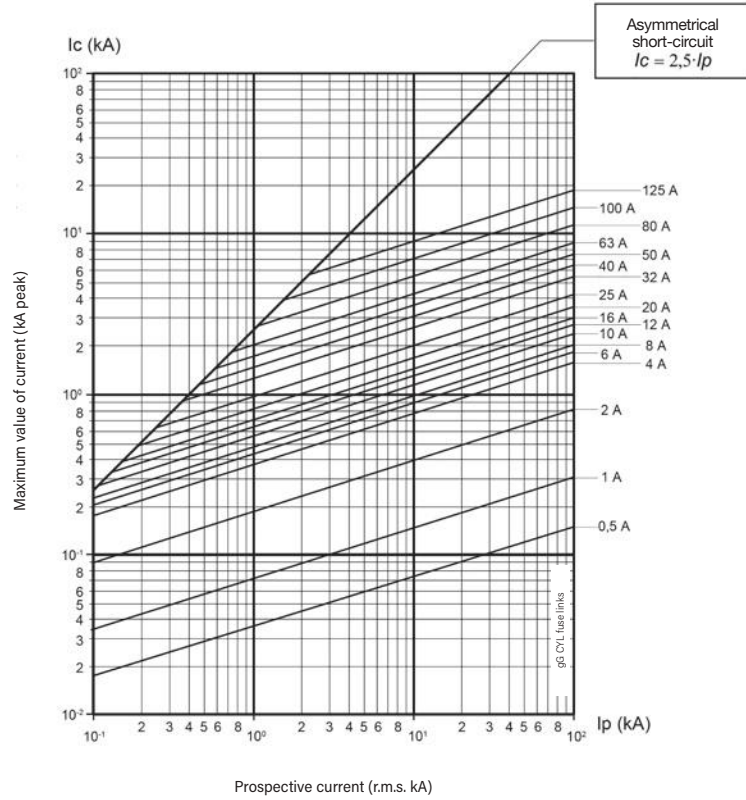

## I<sup>2</sup>t CHARACTERISTICS

RATED CURRENT (A)	PREARcing I <sup>2</sup> t (A <sup>2</sup> s)	I <sup>2</sup> t 400V (W @ I <sub>n</sub> )	I <sup>2</sup> t 500V (A <sup>2</sup> s)	I <sup>2</sup> t 690V (A <sup>2</sup> s)
0,5	4,0	8,6	10,4	15,0
1	6,5	13,2	15,7	22,0
2	7,0	14,6	17,6	25,0
4	45	90	108	150
6	70	140	166	230
8	80	158	188	260
10	120	248	297	420
12	180	362	431	600
16	270	536	636	880
20	500	981	1.162	1.600
25	800	1.688	2.034	2.900
32	1.200	2.412	2.871	4.000
40	2.500	4.907	5.808	8.000
50	5.100	11.262	13.728	20.000
63	7.900	16.451	19.762	28.000
80	16.000	37.242	46.000	-
100	28.000	68.072	85.000	-
125	40.000	120.000	-	-

**aM** | **gG**  
CYLINDRICAL  
fuse links



## DIMENSIONS

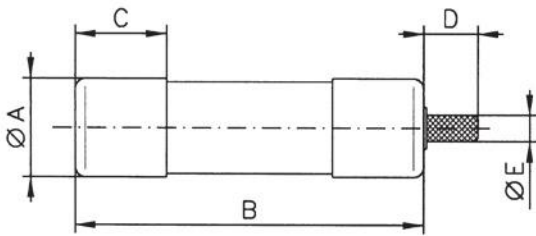

	A	B	C	D	E
<b>8x32</b>	8,5	31,5	6,3	-	-
<b>10x38</b>	10,3	38	8,5	-	-
<b>14x51</b>	14,3	51	11,5	8	3,7
<b>22x58</b>	22,2	58	15,5	8	3,7

## TECHNICAL DATA

	RATED VOLTAGE	RATED CURRENT	BREAKING CAPACITY
<b>8x32</b>	400V	1A...10A	20kA
<b>10x38</b>	500V 400V	0,16A...16A 20A   25A	120kA 120kA
<b>14x51</b>	690V 500V 400V	1A...25A 32A...45A 50A	80kA 120kA 120kA
<b>22x58</b>	690V 500V 400V	2A...63A 80A   100A 125A	80kA 120kA 120kA

## POWER DISSIPATION

RATED CURRENT (A)	<b>8x32</b> (W)	<b>10x38</b> (W)	<b>14x51</b> (W)	<b>22x58</b> (W)
<b>0,16</b>	-	0,24	-	-
<b>0,25</b>	-	0,36	0,41	-
<b>0,5</b>	-	0,49	0,69	-
<b>1</b>	0,10	0,10	0,14	-
<b>2</b>	0,16	0,18	0,24	0,29
<b>4</b>	0,25	0,31	0,45	0,48
<b>6</b>	0,35	0,32	0,42	0,47
<b>8</b>	0,40	0,52	0,70	0,73
<b>10</b>	0,65	0,55	0,53	0,74
<b>12</b>	-	0,63	0,88	0,83
<b>16</b>	-	0,92	1,16	1,21
<b>20</b>	-	0,96	1,23	1,29
<b>25</b>	-	1,40	1,46	1,53
<b>32</b>	-	-	2,04	2,13
<b>40</b>	-	-	2,60	3,40
<b>45</b>	-	-	2,85	-
<b>50</b>	-	-	2,90	3,48
<b>63</b>	-	-	-	4,46
<b>80</b>	-	-	-	5,86
<b>100</b>	-	-	-	6,61
<b>125</b>	-	-	-	8,42

## t-I CHARACTERISTICS

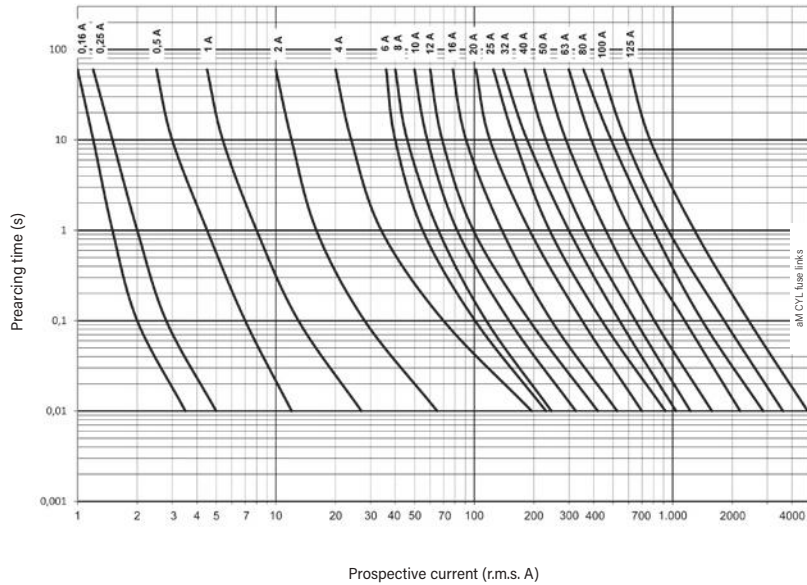

## CUT-OFF CHARACTERISTICS

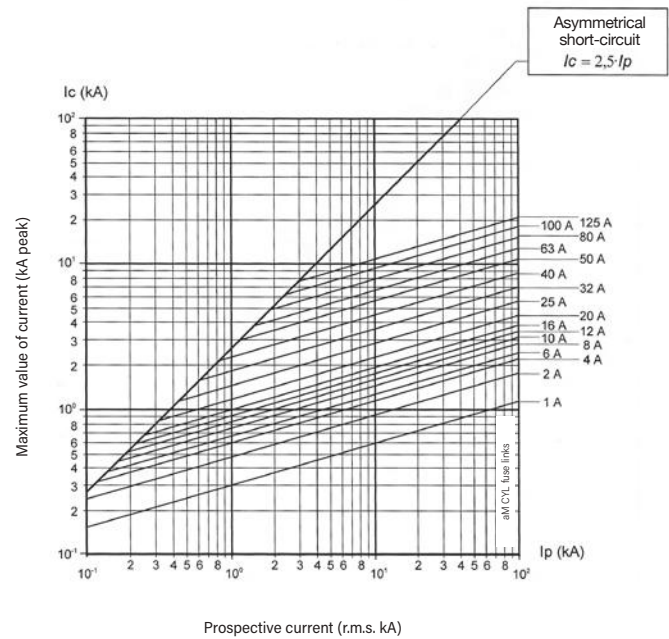

## I<sup>2</sup>t CHARACTERISTICS

RATED CURRENT (A)	PREARcing I <sup>2</sup> t (A <sup>2</sup> s)	I <sup>2</sup> t 400V (W @ I <sub>n</sub> )	I <sup>2</sup> t 500V (A <sup>2</sup> s)	I <sup>2</sup> t 690V (A <sup>2</sup> s)
0,16	3,0	6,7	8,2	12,0
0,25	4,0	8,6	10,4	15,0
0,5	6,5	13,2	15,7	22,0
1	9,5	18,5	21,9	30,0
2	40	83	99	140
4	90	181	215	300
6	120	250	300	425
8	220	448	535	750
10	300	733	916	1.400
12	380	936	1.173	1.800
16	550	1.608	2.103	3.500
20	950	2.488	3.165	5.000
25	1.300	3.728	4.851	8.000
32	2.500	6.207	7.791	12.000
40	4.500	10.685	13.263	20.000
45	8.000	16.538	19.831	28.000
50	10.000	19.626	23.230	32.000
63	15.000	31.520	37.950	54.000
80	30.000	59.088	70.000	-
100	50.000	113.945	140.000	-
125	80.000	200.000	-	-

# CYLINDRICAL

FUSE LINKS & FUSE HOLDERS



<b>RATED CURRENT</b>	25 A	32 A	50 A	100 A
<b>RATED VOLTAGE</b>	400 V	690 V AC 750 V DC	690 V	690 V
<b>RATED POWER DISSIPATION</b>	2,5 W	3 W	5 W	9,5 W
<b>UTILIZATION CATEGORY</b>	AC-22B 400 V	AC-22B 500 V AC-21B 690 V DC-20B 750 V DC	AC-22B 500 V AC-21B 690 V	AC-21B 690 V
<b>PROTECTION DEGREE</b>	IP-20	IP-20	IP-20	IP-20
<b>OPERATING TEMPERATURE</b>	-20 ... 70 °C	-20 ... 70 °C	-20 ... 70 °C	-20 ... 70 °C
<b>STORAGE TEMPERATURE</b>	-40 ... 80 °C	-40 ... 80 °C	-40 ... 80 °C	-40 ... 80 °C
<b>DERATING TEMPERATURE</b>	20 °C	1	1	1
	30 °C	0,95	0,95	0,95
	40 °C	0,9	0,9	0,9
	50 °C	0,8	0,8	0,8
<b>DERATING N° OF POLES</b>	1 ... 4	1	1	1
	5 ... 6	0,8	0,8	0,8
	7 ... 9	0,7	0,7	0,7
	≥ 10	0,6	0,6	0,6
<b>FIXING</b>	<b>RAIL DIN / EN</b>	•	•	•
	<b>SCREW</b>	-	-	-
<b>CONNECTING WIRE</b>		0,75...16 mm <sup>2</sup> STRANDED	0,75...16 mm <sup>2</sup> STRANDED	1,5...25 mm <sup>2</sup> STRANDED
		0,75...16 mm <sup>2</sup> SOLID	0,75...16 mm <sup>2</sup> SOLID	1,5...35 mm <sup>2</sup> SOLID
<b>WITH LIGHTNING INDICATOR</b>		120...400V AC	120...690V AC 12...24V DC	230...690V AC 24...60 VDC
<b>MAX. TIGHTENING TORQUE</b>		2,5 Nm	2,5 Nm	3 Nm
<b>WITH MICROSWITCH 5A-250V</b>	<b>FUSING</b>	-	-	•
	<b>PREBREAKING PRESENCE FUSING</b>	-	-	•
<b>MULTIPOLAR UNION WITH ACCESSORIES</b>		•	•	•
<b>LABEL HOLDER</b>		•	•	•
<b>LOCKING ACCESSORIES</b>		•	•	•

STANDARDS



# CYLINDRICAL

FUSE LINKS & FUSE HOLDERS



PMC 8x32



PMC 10x38



PMF 10x38



PMX-CC CC CLASS

<b>RATED CURRENT</b>	25 A	32 A	32 A	30 A
<b>RATED VOLTAGE</b>	400 V	690 V	690 V	600 V
<b>RATED POWER DISSIPATION</b>	3 W	3 W	3 W	3 W
<b>UTILIZATION CATEGORY</b>	AC-20	AC-20	AC-22B 500V AC-21B 690 V	-
<b>PROTECTION DEGREE</b>	IP-20	IP-20	IP-20	IP-20
<b>OPERATING TEMPERATURE</b>	-20 ... 70 °C	-20 ... 70 °C	-20 ... 70 °C	-20 ... 70 °C
<b>STORAGE TEMPERATURE</b>	-40 ... 80 °C	-40 ... 80 °C	-40 ... 80 °C	-40 ... 80 °C
<b>DERATING TEMPERATURE</b>	20 °C	1	1	1
	30 °C	0,95	0,95	0,95
	40 °C	0,9	0,9	0,9
	50 °C	0,8	0,8	0,8
	60 °C	0,7	0,7	0,7
<b>DERATING N° OF POLES</b>	1 ... 4	1	1	1
	5 ... 6	0,8	0,8	0,8
	7 ... 9	0,7	0,7	0,7
	≥ 10	0,6	0,6	0,6
<b>FIXING</b>	RAIL DIN / EN	•	•	•
	SCREW	-	-	-
<b>CONNECTING WIRE</b>	0,75...6 mm <sup>2</sup> STRANDED	0,75...6 mm <sup>2</sup> STRANDED	0,75 ... 16 mm <sup>2</sup> STRANDED 0,75 ... 25 mm <sup>2</sup> SOLID	0,75...16 mm <sup>2</sup> STRANDED
	0,75...10 mm <sup>2</sup> SOLID	0,75...10 mm <sup>2</sup> SOLID	0,75...10 mm <sup>2</sup> STRANDED (1P+N 1M) 0,75...16 mm <sup>2</sup> SOLID (1P+N 1M)	0,75...16 mm <sup>2</sup> SOLID
<b>WITH LIGHTNING INDICATOR</b>	-	-	120...690V AC 12...24V DC	120...690V AC 12...24V DC
<b>MAX. TIGHTENING TORQUE</b>	2 Nm	2 Nm	2,5 Nm 2 Nm (1P+N 1M)	2,5 Nm
<b>WITH MICROSWITCH 5A-250V</b>	FUSING	-	-	•
	PREBREAKING PRESENCE	-	-	•
	FUSING	-	-	•
<b>MULTIPOLAR UNION WITH ACCESSORIES</b>	•	•	•	•
<b>LABEL HOLDER</b>	-	-	-	•
<b>LOCKING ACCESSORIES</b>	-	-	-	•

STANDARDS





## CYLINDRICAL fuse holders

### UNION MULTIPOLAR

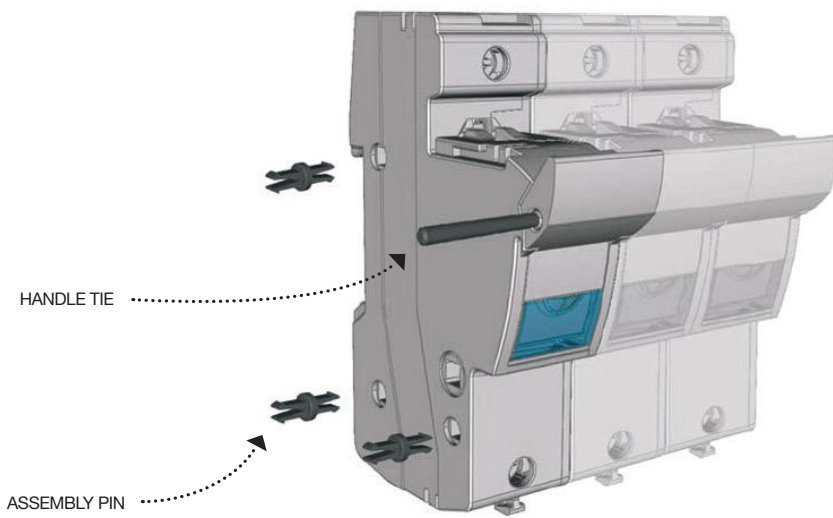

### MONTAJE MICRORRUPTOR

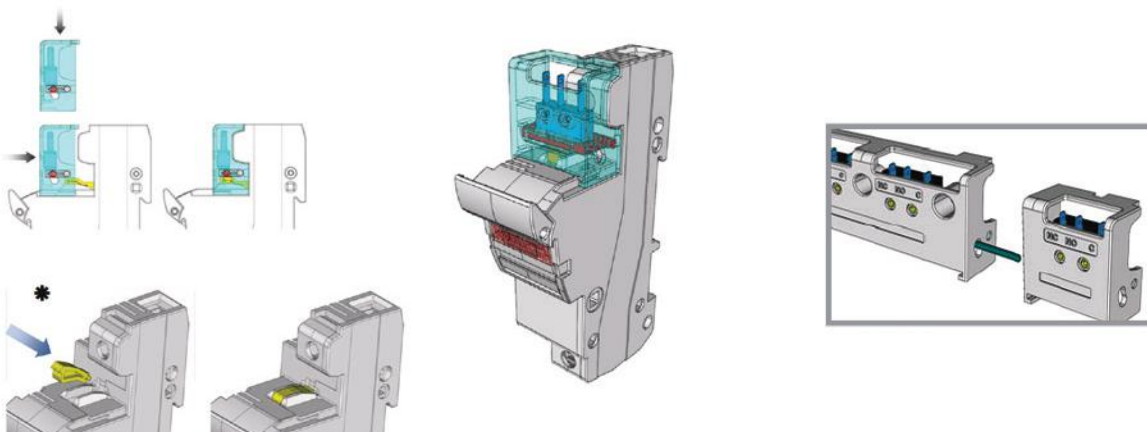

Put on the **microswitch** on the guides, and push in horizontal movement to the final position.

\* For **ONLY FUSION** accessory, first mount the lifter in his place.



## PMX CYLINDRICAL fuse holders

RATED VOLTAGE	RATED CURRENT	PROTECTION INDEX
400V	25A	IP20
690V AC 750V DC	32A	
24V DC	32A	



**PATENTED  
DESIGN**

## DIMENSIONS

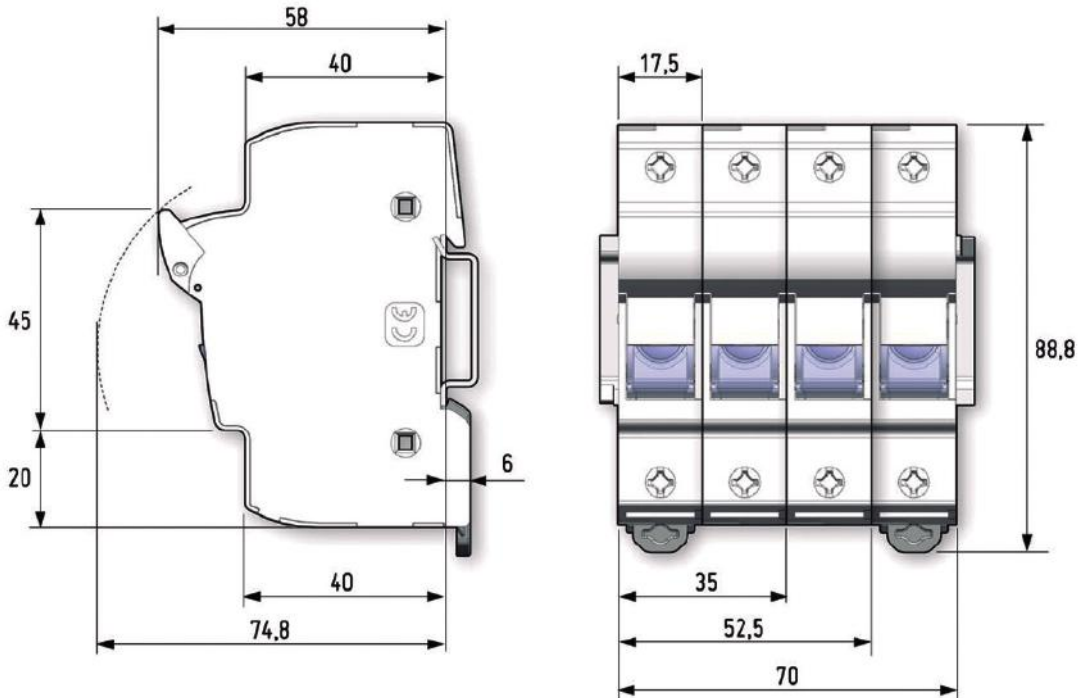



PMX

14x51

**PMX**  
CYLINDRICAL  
fuse holders

RATED VOLTAGE	RATED CURRENT	PROTECTION INDEX
690V AC	50A	IP20
24V DC		



**PATENTED  
DESIGN**

## DIMENSIONS

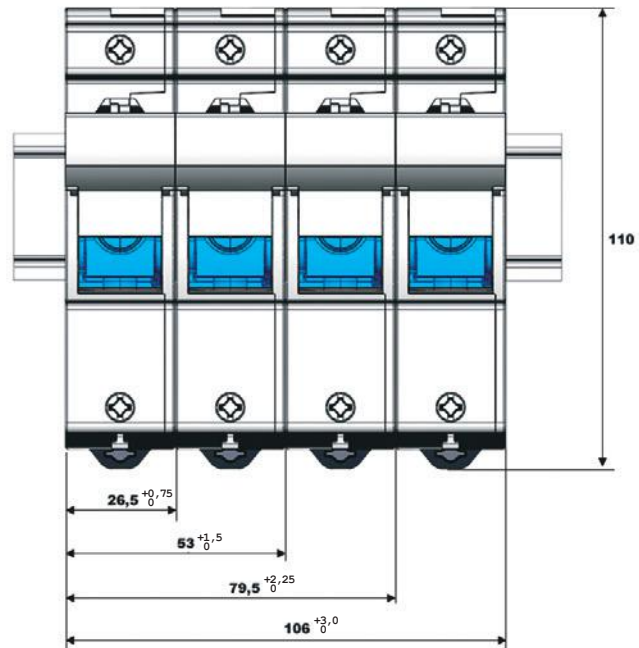
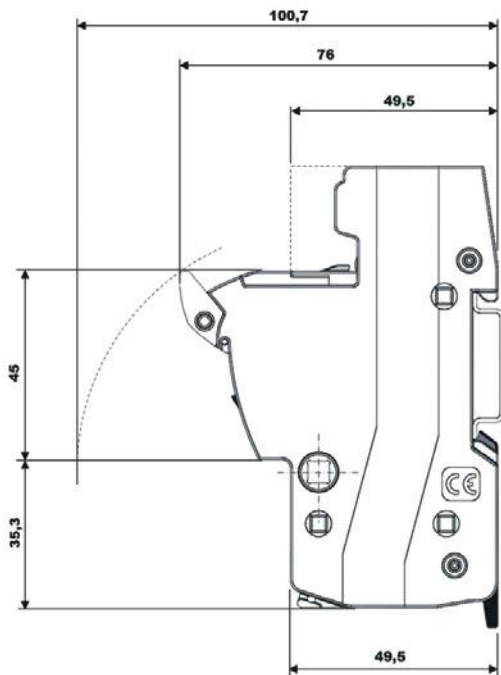

PMX

22x58

**PMX**  
CYLINDRICAL  
fuse holders

RATED VOLTAGE	RATED CURRENT	PROTECTION INDEX
690V AC 24V DC	100A	IP20

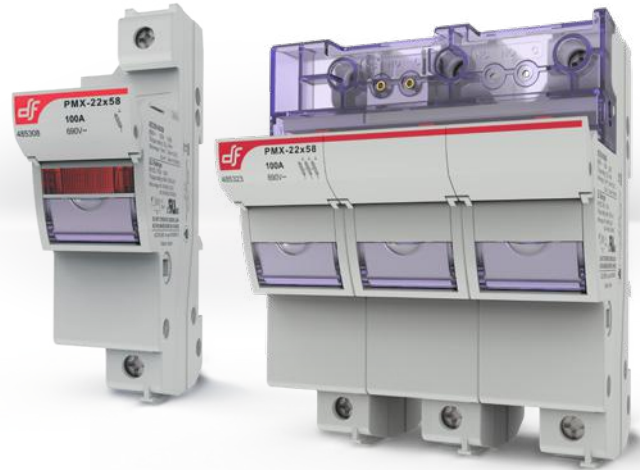

**PATENTED  
DESIGN**

## DIMENSIONS

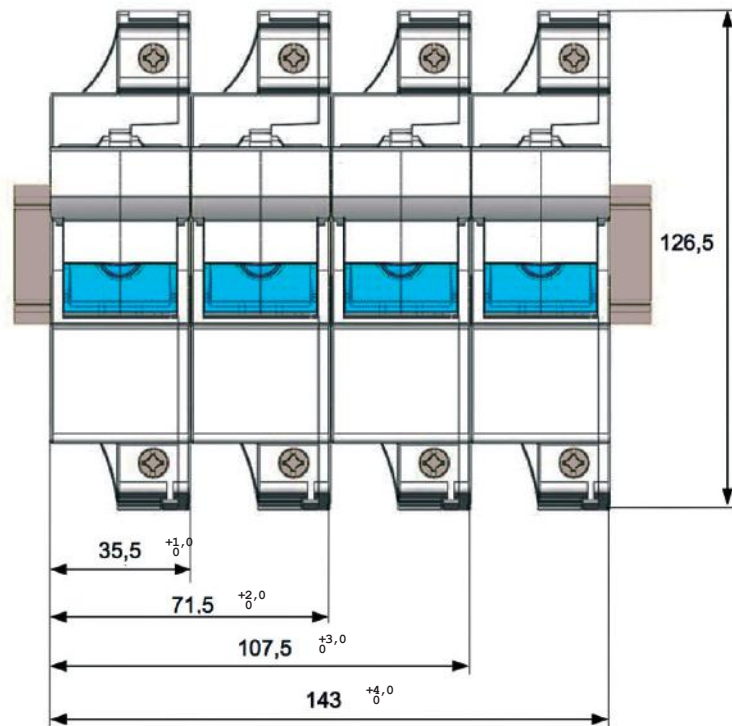
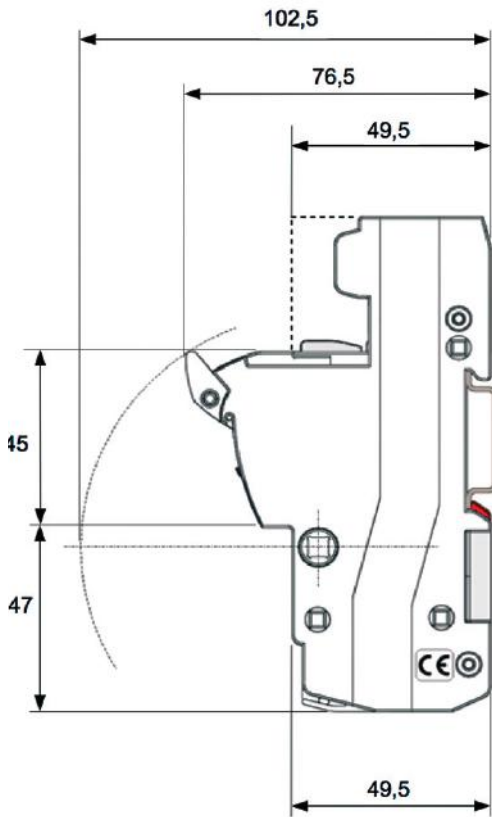

**PMX** | **PMX**  
CYLINDRICAL  
fuse holders

## ACCESSORIES

### IDENTIFICATION BY LABEL

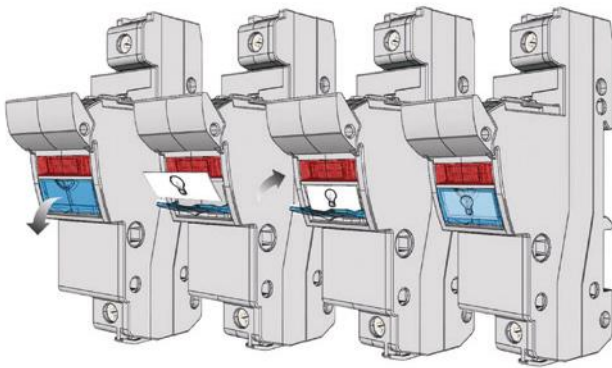

Open the label-holder part when the fuse holder is totally closed or totally open, put on the label and close.

### PHASE SEPARATOR

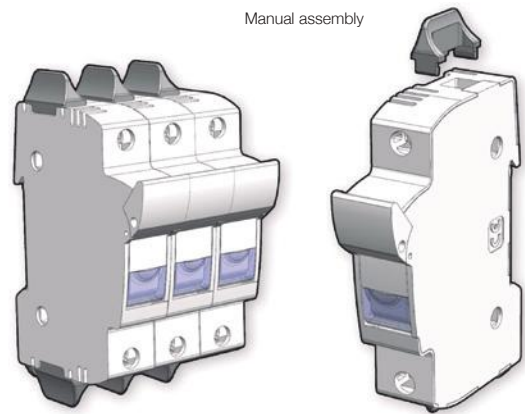

The accessory increases the distance between phases in multipolar assemblies.

### LOCKING MEANS A PADLOCK

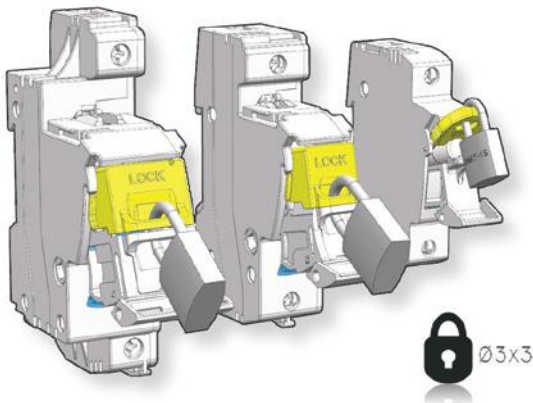

To avoid the operation and connection when the fuse holder is open, put on the accessory "Padlock support" sliding it for the guides, and covering the fuse link zone.

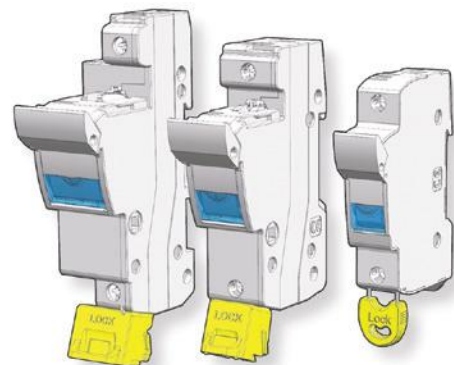

Introduce the padlock trough the symmetrical holes and close it.  
*(Is possible the use with or without fuse link)*

## SPECIAL IP20 PROTECTION

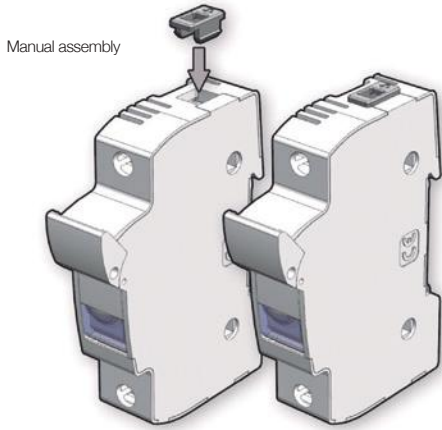

The accessory must be positioned in the wire entries, if it's necessary to achieve the IP20 degree of protection with thin wires.

	SECTION FLEXIBLE WIRE (mm <sup>2</sup> )	SECTION SOLID WIRE (mm <sup>2</sup> )	LENGTH (mm)
<b>8x32</b>	≤6	≤10	10
<b>10x38</b>	≤6	≤10	10
<b>14x51</b>	≤10	≤16	14
<b>22x58</b>	≤16	≤25	18

## SCREW PROTECTION

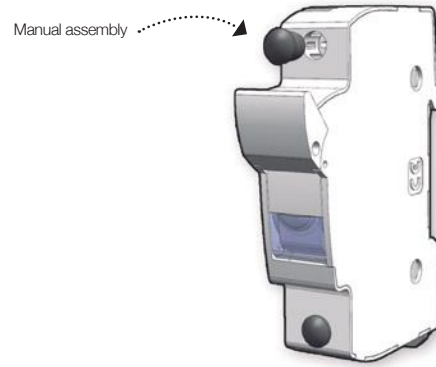

Protection accessory to avoid the screws manipulation and improve the protection degree.

## SCREW FIXATION

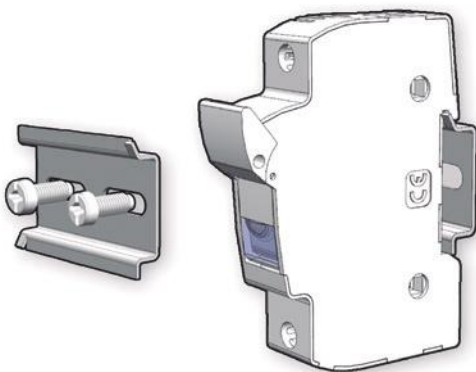

First mount the accessory with screws, then mount the fuseholder. (there are available different accessories depending the number of the fuseholder)

REFERENCE	SIZE (mm)
<b>485650</b>	25
<b>485651</b>	50
<b>485652</b>	75
<b>485653</b>	100
<b>485654</b>	125
<b>485655</b>	175

## ACCESSORY SCREW CONNECTION

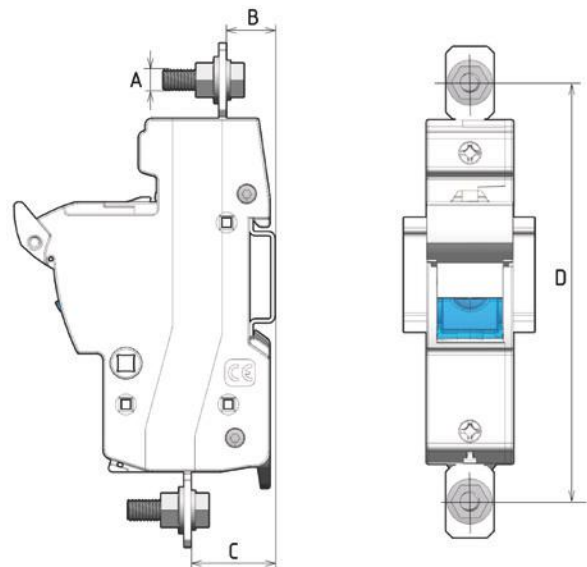

REFERENCE	A (mm)	B (mm)	C (mm)	D (mm)
<b>14x51</b>	M6	14,5	25	128,5
<b>22x58</b>	M8	15	23,5	154,5

**PMC** CYLINDRICAL fuse holders

RATED VOLTAGE	RATED CURRENT	PROTECTION INDEX
400V	25A	IP20
500V	32A	



**PATENTED DESIGN**

## DIMENSIONS

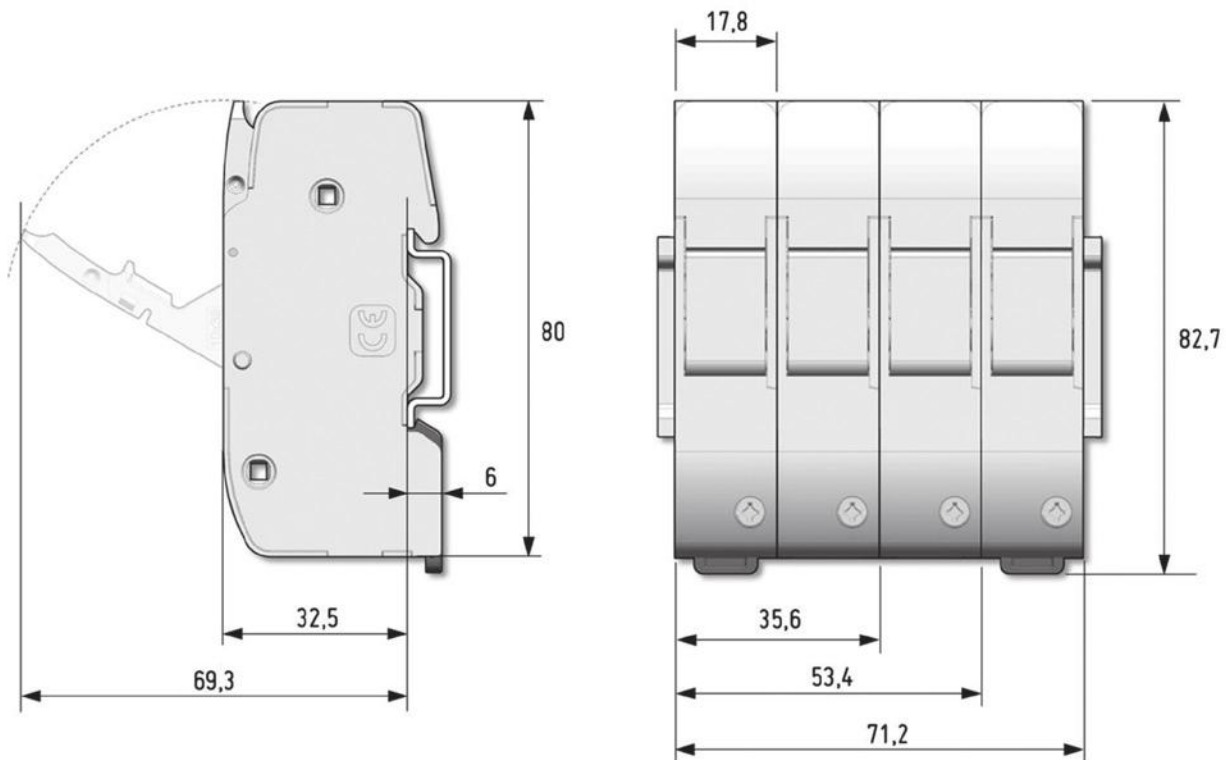

**PMF** CYLINDRICAL fuse holders

RATED VOLTAGE	RATED CURRENT	PROTECTION INDEX
690V	32A	IP20
400V	32A	



## DIMENSIONS

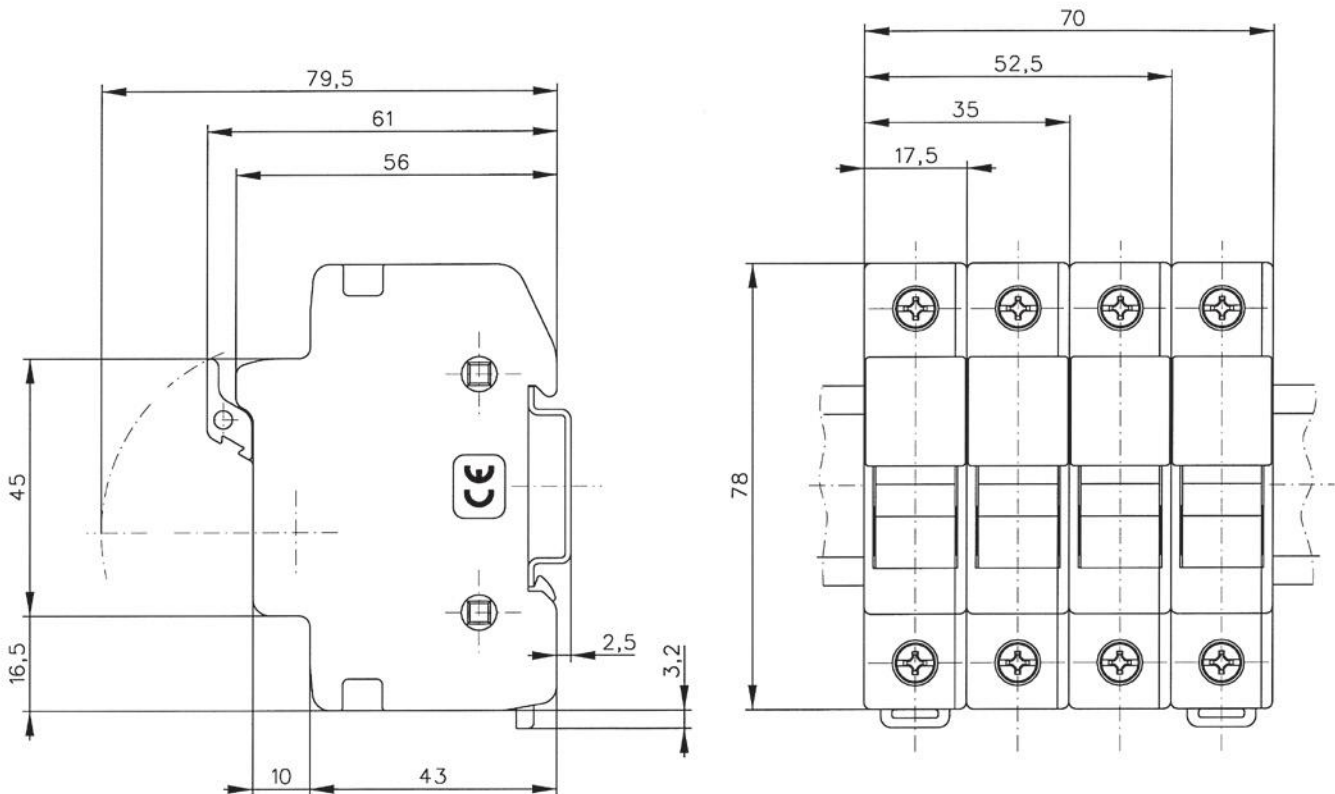



## PMX CC CLASS CYLINDRICAL fuse holders

RATED VOLTAGE	RATED CURRENT	PROTECTION INDEX
600V	30A	IP20



**PATENTED  
DESIGN**

### DIMENSIONS

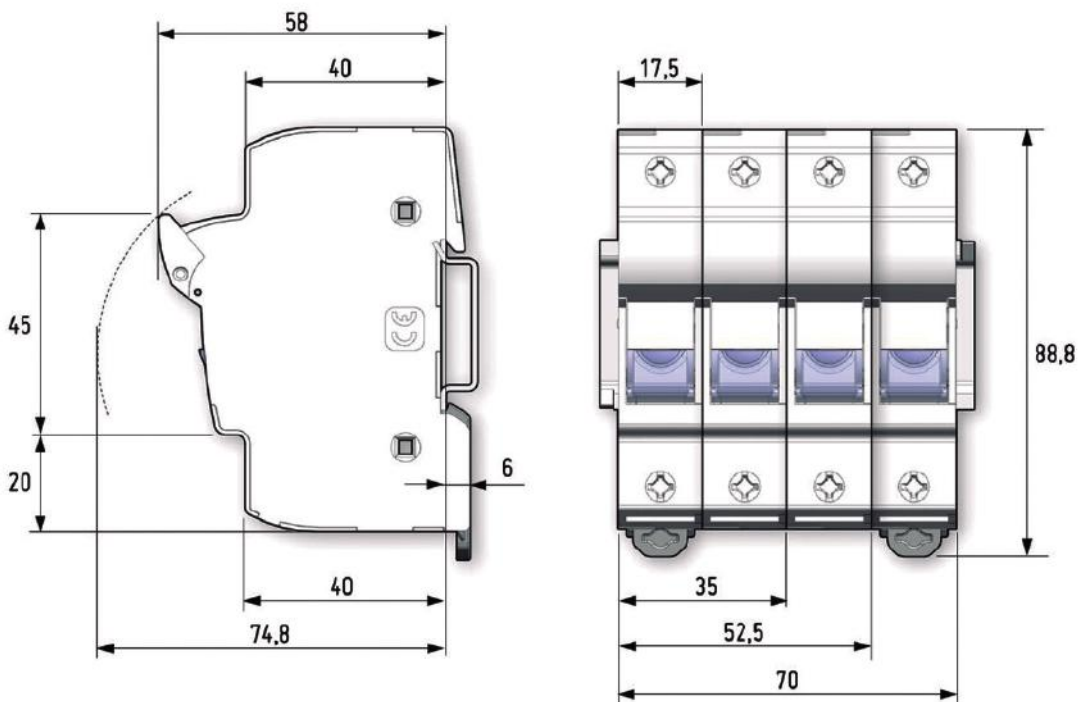



## CLIP CONTACT CYLINDRICAL Ø10 fuse links

	RATED VOLTAGE	RATED CURRENT	RATED POWER DISSIPATION
UP TO	1500V AC/DC	25A	4W

### DIMENSIONS

	L (mm)
10x38	32
10x85	79,6

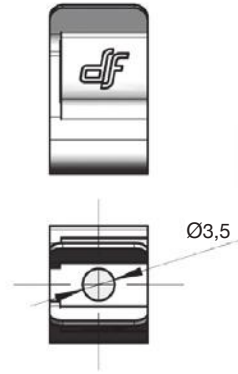
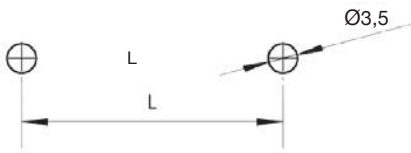

	L (mm)
10x38	42
10x85	89,6

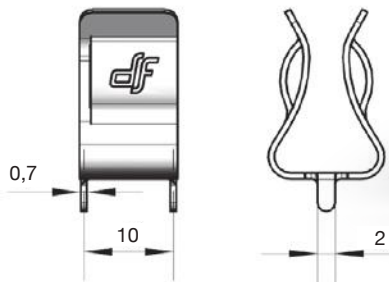
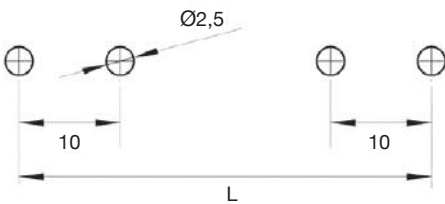





## DC APPLICATIONS

Fuses are generally suitable for both AC and DC applications. The DC performance of fuse links is different and AC ratings cannot be used for DC applications. There is no simple rule that safely converts an AC voltage rating of a fuse link to DC voltage rating. For this reason it is necessary to take into account a lot of aspects in order to determine the DC applications.

In the **DF ELECTRIC gG Cylindrical fuse links** it is necessary to take into account the following considerations:

- The power dissipations are the same in AC (RMS value) and the DC values.
- The time current characteristics are the same for DC applications under steady-state conditions.
- The DC rated voltage and maximum breaking capacity are lower than the AC values (*see the table*).

	RATED CURRENT	MAX. DC VOLTAGE	DC BREAKING CAPACITY
<b>8,5x31,5</b>	0,5A...10A 12A...20A	150V DC 60V DC	5 kA
<b>10x38</b>	0,5A...16A 20A...32A	250V DC 80V DC	15 kA
<b>14x51</b>	1A...25A 32A & 40A 50A	440V DC 80V DC 48V DC	15 kA
<b>22x58</b>	2A...63A 80A & 100A 125A	440V DC 80V DC 48V DC	15 kA

### NOTES

These values are referred to a time constant L/R = 15 ms.

For higher values of time constant, the maximum utilization voltage must be reduced.

For circuits with very inductive behaviour, we recommend to connect two fuses in series.



**HEAD OFFICE AND FACTORY**

SILICI, 67-69  
08940 CORNELLA DE LLOBREGAT  
BARCELONA  
SPAIN  
Tel. +34 93 377 85 85  
Fax +34 93 377 82 82

**INTERNATIONAL SALES**

Tel. +34 93 475 08 64  
Fax +34 93 480 07 75  
export@df-sa.es

**NATIONAL SALES**

Tel. 93 475 08 64  
Fax 93 480 07 76  
comercial@df-sa.es

[www.df-sa.es](http://www.df-sa.es)



**PROTECTING  
THE WORLD**

