

Acuvim L Series

Multifunction Power Meters



FEATURES

- Metering of Distribution Feeders, Transformers, Generators, Capacitor Banks and Motors
- Medium and Low Voltage Systems
- Commercial, Industrial, Utility
- Power Quality Analysis





ISO9001 Certified



 UL & cUL Certified

 IP54
The front panel protection level is IP54

 0.5s
Active energy accuracy is 0.5s

 Power quality analysis



MULTI-PLATFORM ACCESS

Built-in web server provides computer, tablet and smartphone access.

DESCRIPTION

The Acuvim-L series are multifunction power meters manufactured by Accuenergy. It is the ideal choice for monitoring and controlling of power distribution system. Some of the features and electric power parameters available on the Acuvim-L are:

- True-RMS Measuring Parameter
- Power Quality Analysis
- Energy Pulse Output
- 4-quadrant Energy
- Over/Under Limit Alarm
- TOU, 4 Tariffs, 12 Seasons, 14 Schedules

APPLICATIONS

- Metering of distribution feeders, transformers, generators, capacitor banks and motors
- Medium and low voltage systems
- Commercial, industrial, utility
- Power quality analysis

FEATURES

Metering

- **Voltage:** Uln 1, Uln 2, Uln 3, Uln avg, Ull 12, Ull 23, Ull 31, Ull avg
- **Current:** I1, I2, I3, In, I4, I tot, I avg
- **Active Power:** watt 1, watt 2, watt 3, watt tot
- **Reactive Power:** var 1, var 2, var 3, var tot
- **Apparent Power:** va 1, va 2, va 3, va tot
- **Power Factor:** PF1, PF2, PF3, PF
- **Frequency:** F
- **Active Energy:** Watt-hour Imp, Watt-hour Exp, Watt-hour Imp+Exp, Watt-hour Imp-Exp, Watthour Q1, Watt-hour Q2, Watt-hour Q3, Watt-hour Q4, Watt-hour Imp 1, Watt-hour Exp 1, Watt-hour Imp 2, Watt-hour Exp 2, Watt-hour Imp 3, Watthour Exp 3
- **Reactive Energy:** Var-hour Imp, Var-hour Exp, Var-hour Imp+Exp, Var-hour Imp-Exp, Var-hour Q1, Var-hour Q2, Var-hour Q3, Var-hour Q4, Varhour Imp 1, Var-hour Exp 1, Var-hour Imp 2, Varhour Exp 2, Var-hour Imp 3, Var-hour Exp 3
- **Apparent Energy:** VA-hour Imp, VA-hour Exp, VAhour Imp+Exp, VA-hour Imp-Exp, VA-hour Q1, VAhour Q2, VA-hour Q3, VA-hour Q4, VA-hour Imp 1, VA-hour Exp 1, VA-hour Imp 2, VA-hour Exp 2, VAhour Imp 3, VA-hour Exp 3
- **Current Demand:** I1_Dmd, I2_Dmd, I3_Dmd, I4_Dmd, I1_Pre_Dmd, I2_Pre_Dmd, I3_Pre_Dmd, I4_Pre_Dmd
Power Demand: P_Dmd, Q_Dmd, S_Dmd, P_Pre_Dmd, Q_Pre_Dmd, S_Pre_Dmd
- **Load Features**
- **Four Quadrant Powers**

Monitoring

- Power Quality
- Voltage Harmonics
 - 2nd ~ 31st for BL and CL;
 - 2nd ~ 63rd for EL
- Current Harmonics
 - 2nd ~ 31st for BL and CL;
 - 2nd ~ 63rd for EL
- Voltage Unbalance Factor U_unbl
- Current Unbalance Factor I_unbl
- Max/Min Statistics
- Meter Running Time and Load Running Time

Alarm

Two (2) parameters may be set within a specified time interval. If indicated parameter is over or under its setting limit and persists over the specified time interval, the event will be recorded with time stamps and trigger the alarm DO output.

The indicated parameter can be selected from any of the 51 parameters available.

I/O option module

The Acuvim-CL/EL model can extend the I/O module. Digital input, pulse counter, pulse output and SOE can be provided by extension I/O module.

Pulse Output option

Two digital outputs can be configured as pulse output for kWh and kvarh. The pulse rate and width can be set.



Acuvim-L may be used as a data gathering device for an intelligent Power Distribution System or a Plant Automation System. All monitoring data is available via digital RS485 communication port running Modbus® Protocol.

The quality of the power system is important with increasing use of electronic loads such as computers, ballasts or variable frequency drives. With the Acuvim-L power analysis option, any phase current or voltage can be displayed and the harmonic content calculated. By knowing the harmonic distribution, action can be taken to prevent overheated transformers, motors, capacitors, neutral wires and nuisance breaker trips. Redistribution of the system loading can also be determined.

Power Quality Event Logging

When a power quality event happens, such as voltage sag and fail, etc., Acuvim-EL will record the timestamp and the triggering condition of the event. It can save 16 power quality events.

Time of Use

Users can assign up to 4 different tariffs (sharp, peak, valley and normal) to different time periods within a day according to the billing requirements. The Acuvim-EL meter will calculate and accumulate energy to different tariffs according to the meter's internal clock timing and TOU settings.

Flexible Current Input

Compatible with different current transformers such as 5A, 1A, 333mV output CT and Rogowski coil all available from Accuenergy.

Wiring Check

The Acuvim - L series meter has the function of wiring check, according to the setting of wiring mode, load features and PF value.

Communication

Ethernet module provides RJ45 port with all industrial standard protocols such as Modbus-TCP/IP, DNP 3.0 Over IP V2, BACnet-IP, SNMP V3.

Data post protocol: HTTP/HTTPs post, FTP post

Built-in Encrypted Webserver: HTTPs webserver;
4GB Datalogging memory

FUNCTION LIST

● Function ⊙ Option Blank NA

	Function	Parameter	Acuvim-BL	Acuvim-CL	Acuvim-EL
REAL TIME METERING	Line to Neutral Voltages Uln	Uln 1, Uln 2, Uln 3, Uln avg	●	●	●
	Line to Line Voltages Ull	Ull 12, Ull 23, Ull 31, Ull avg	●	●	●
	Current	I 1, I 2, I 3, I n, I 4, I avg, I tot	●	●	●
	Active Power	watt 1, watt 2, watt 3, watt tot	●	●	●
	Reactive Power	var 1, var 2, var 3, var tot	●	●	●
	Apparent Power	va 1, va 2, va 3, va tot	●	●	●
	Power Factor	PF 1, PF 2, PF 3, PF	●	●	●
	Load Nature	L/C/R	●	●	●
	Frequency	F	●	●	●
ENERGY	Active Energy	Watt-hour Imp, Watt-hour Exp, Watt-hour Imp+Exp, Watt-hour Imp-Exp	●	●	●
		Watt-hour Q1, Watt-hour Q2, Watt-hour Q3, Watt-hour Q4		●	●
	Reactive Energy	Var-hour Imp, Var-hour Exp, Var-hour Imp+Exp, Var-hour Imp-Exp	●	●	●
		Var-hour Q1, Var-hour Q2, Var-hour Q3, Var-hour Q4		●	●
	Apparent Energy	VA-hour Imp, VA-hour Exp, VA-hour Imp+Exp, VA-hour Imp-Exp	●	●	●
		VA-hour Q1, VA-hour Q2, VA-hour Q3, VA-hour Q4		●	●
	Single-Phase Active Energy	Watt-hour Imp 1, Watt-hour Exp 1, Watt-hour Imp 2, Watt-hour Exp 2, Watt-hour Imp 3, Watt-hour Exp 3		●	●
	Single-Phase Reactive Energy	Var-hour Imp 1, Var-hour Exp 1, Var-hour Imp 2, Var-hour Exp 2, Var-hour Imp 3, Var-hour Exp 3		●	●
Single-Phase Apparent Energy	VA-hour Imp 1, VA-hour Exp 1, VA-hour Imp 2, VA-hour Exp 2, VA-hour Imp 3, VA-hour Exp 3		●	●	
DEMAND	Current Demand, Current Predicted Demand	I 1_Dmd, I 2_Dmd, I 3_Dmd, I 4_Dmd, I 1_Pre_Dmd, I 2_Pre_Dmd, I 3_Pre_Dmd, I 4_Pre_Dmd	●	●	●
	Power Demand, Power Predicted Demand	P_Dmd, Q_Dmd, S_Dmd, P_Pre_Dmd, Q_Pre_Dmd, S_Pre_Dmd	●	●	●
TIME	Real Time Clock	Year, Month, Date, Hour, Minute, Second	●	●	●
HOUR	Meter Running Time	Hour	●	●	●
	Load Running Time	Hour	●	●	●
WIRING CHECK	Voltage/Current Wiring	Each phase of V & I loss or error	●	●	●
POWER QUALITY	Voltage Unbalance	U_unbl	●	●	●
	Current Unbalance	I_unbl	●	●	●
	Voltage THD	THD_U 1, THD_U 2, THD_U 3	●	●	●
	Current THD	THD_I 1, THD_I 2, THD_I 3	●	●	●
	Individual Harmonics	Harmonics 2 nd to 31 st	●	●	●
		Harmonics 2 nd to 63 rd			●
	Voltage Crest Factor	Crest Factor	●	●	●
TIF	THFF	●	●	●	
Current K Factor	K Factor	●	●	●	
SEQUENCE	Voltage/Current Sequence	Positive Sequence, Negative Sequence, Zero Sequence		●	●
PHASE ANGLES	Voltage/Current Phase Angles	Voltage Phase Angle, Current Phase Angle	●	●	●
STATISTICS	MAX with Time Stamp, MIN with Time Stamp	Each phase of V & I; Total of P, Q, S, PF & F; Demand of I1, I2, I3, I4, P, Q&S; Each phase THD of V & I; Unbalance factor of V & I	●	●	●
ALARM	Over/Under Limit Alarm	V, I, P, Q, S, PF, V_THD & I_THD Each Phase and Total or Average; Unbalance Factor of V & I; Load Type; Demand of I1, I2, I3, P, Q&S; Reverse phase sequence;	●	●	●
POWER QUALITY EVENT LOGGING	Power Quality Event with Time Stamp	Voltage SAG and fail, Current overflow, Phase Sequence error			●
TIME OF USE	Energy/Max Demand	TOU, 4 Tariffs, 12 Seasons, 14 Schedules			●
	DAYLIGHT SAVING TIME	Two Adjustable Formats			●
	Holiday	Holiday setting up to 10 years			●
I/O	Energy Pulse Output	2 DO, configured as pulse output for kWh and kvarh, the pulse rate and width can be set	●		
	IO Module	4DI, 2DO/2RO, SOE, Pulse Counter, Pulse output, Alarm output		⊙	⊙
COMMUNICATION	RS-485	Modbus [®] -RTU Protocol		●	●
	Ethernet RJ45	Modbus-TCP/IP, DNP 3.0 Over IP V2, BACnet-IP, SNMP V3, HTTP/HTTPS post, FTP post, SMTP, NTP, HTTPs webserver; 4GB Datalogging memory		⊙	⊙
	RS-485 Module	Modbus [®] -RTU Protocol		⊙	⊙
	PROFIBUS	PROFIBUS-DP/V0 Protocol		⊙	⊙

TYPICAL WIRING

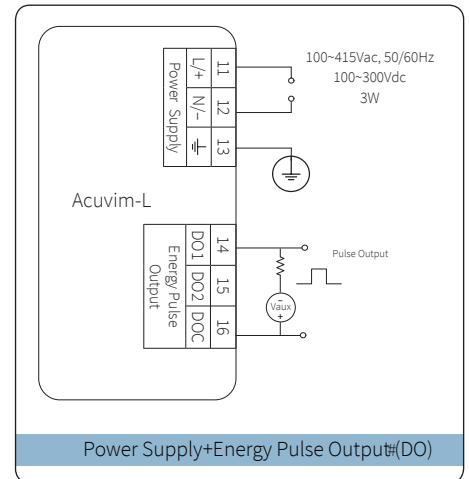
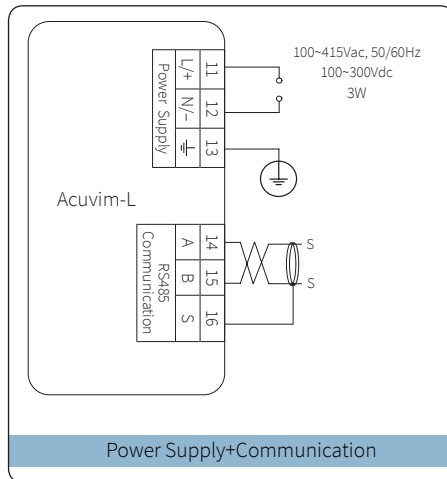
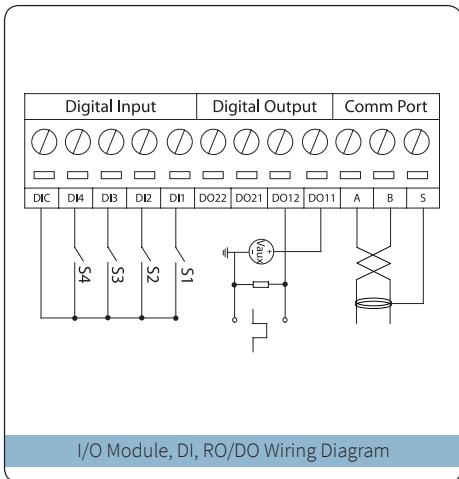
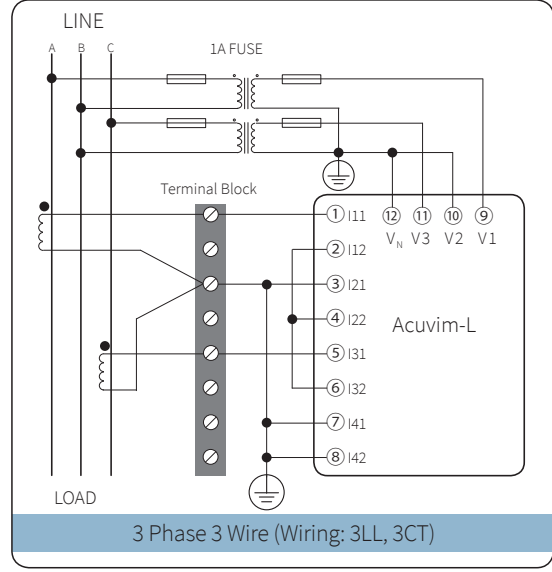
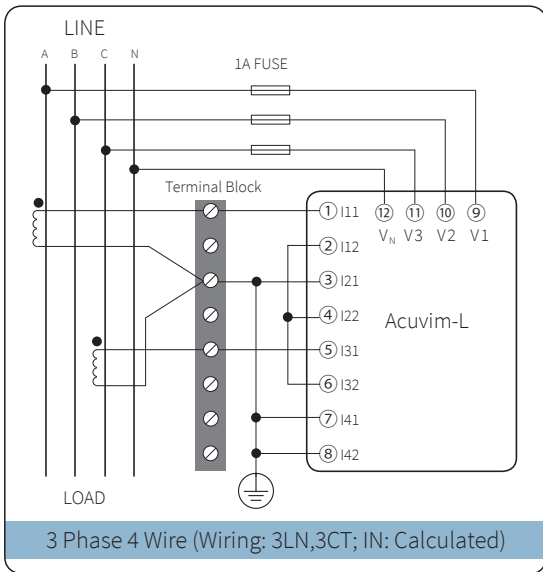
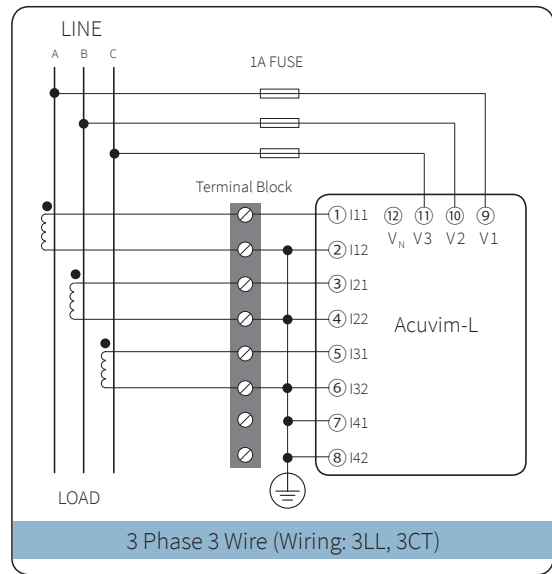
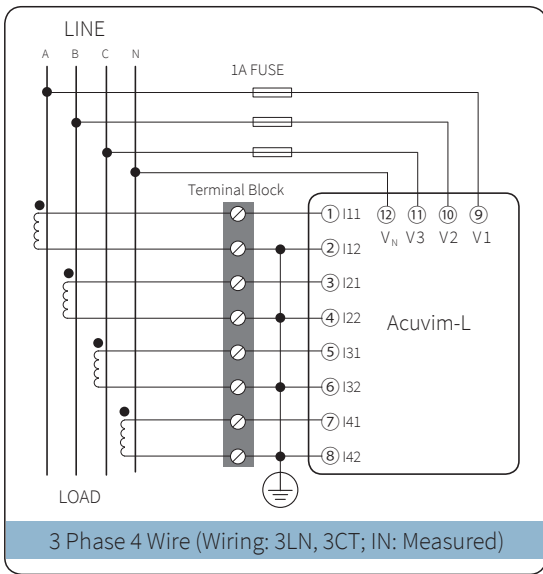

Note: "#" Wiring diagram is only applicable to Acuvim BL.

TYPICAL WIRING RCT*/mV CURRENT INPUT

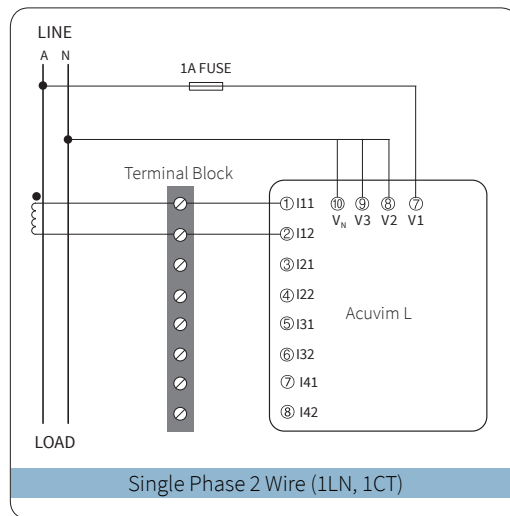
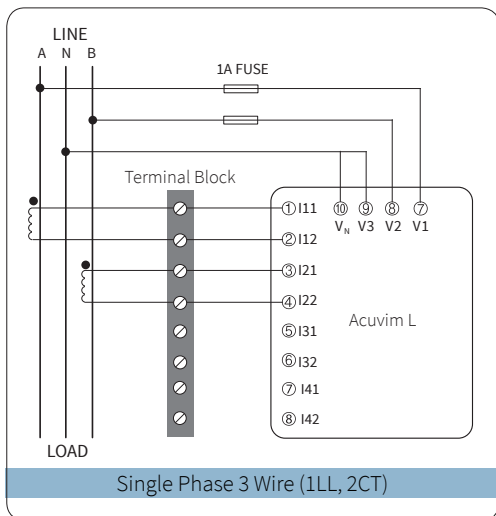
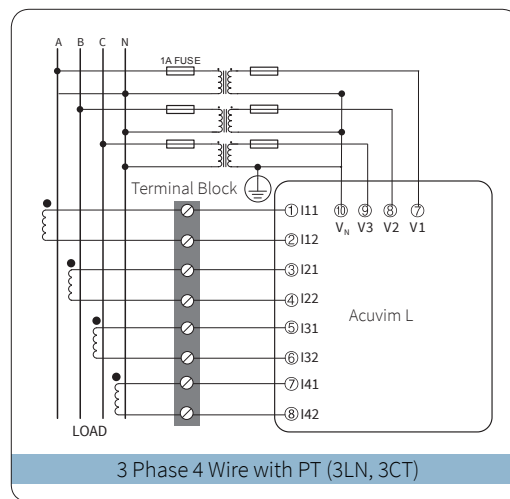
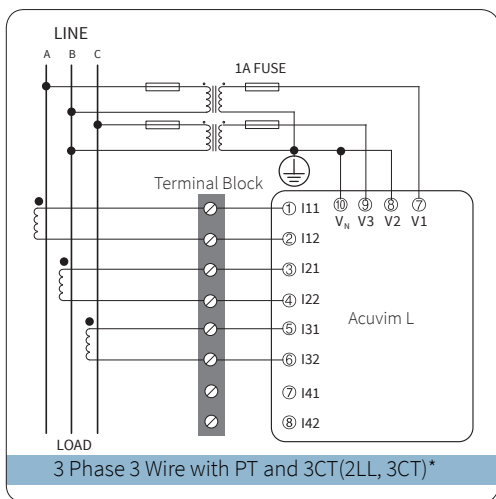
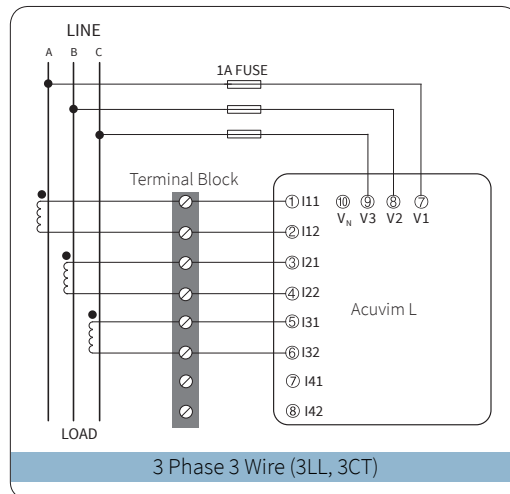
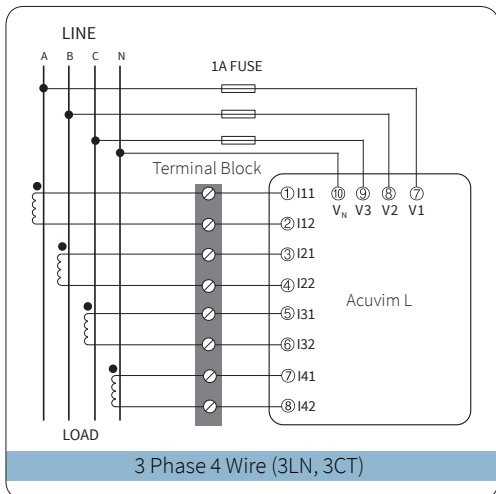

*RCT model doesn't have 4th CT input channel

SPECIFICATIONS

METERING			
Parameters	Accuracy	Resolution	Range
Voltage	0.5%	0.1V	20V~1000kV
Current	0.5%	0.001A	0~50000A
Current Demand	0.5%	0.001A	0~50000A
Power	0.5%	1W	-9999MW~9999MW
Reactive Power	0.5%	1var	-9999Mvar~9999Mvar
Apparent Power	0.5%	1VA	0~9999MVA
Power Demand	0.5%	1W	-9999MW~9999MW
Reactive Power Demand	0.5%	1var	-9999Mvar~9999Mvar
Apparent Power Demand	0.5%	1VA	0~9999MVA
Power Factor	0.5%	0.001	-1.0~1.0
Frequency	0.2%	0.01Hz	45.00~65.00Hz
Energy	0.5%	0.1kWh	0~99999999.9kWh
Reactive Energy	0.5%	0.1kvarh	0~99999999.9kvarh
Apparent Energy	0.5%	0.1VAh	0~99999999.9kVAh
Harmonics	1.0%	0.01%	
Meter Running Time		0.01hrs	0~9999999.99hrs
Load Running Time		0.01hrs	0~9999999.99hrs
Meter Total Running Time		0.01hrs	0~9999999.99hrs

INPUT	
Current Inputs (Each Channel)	
Nominal Current	① 5A, ② 1A, ③ 1A(333mV), ④ 1A(100mV Rope- CT),
Metering Range	① 0~10A, ② 0~2A, ③ 0~1.2A, ④ 0~1.2A,
Pickup Current	① 5mA, ② 1mA, ③ 5mA, ④ 5mA,
Withstand	20Arms continuous 100Arms for 1 second, non-recurring
Burden	0.05VA (typical) @ 5Arms
Accuracy	0.5%

Voltage Inputs (Each Channel)	
Nominal Full Scale	400Vac L-N, 690Vac L-L (+20%)
Withstand	1500Vac continuous 2500Vac, 50/60Hz for 1minute
Input Impedance	2Mohm per phase
Metering Frequency	45Hz~65Hz
Pickup Voltage	10Vac
Accuracy	0.5%

Energy Accuracy	
Active (according to IEC 62053-22)	Class 0.5s
(according to ANSI C12.20)	Class 0.5s
Reactive (according to IEC 62053-23)	Class 2

Harmonic Resolution	
Metered Value	2 nd ~63 rd harmonics

DIGITAL INPUT OPTION	
Digital Input (DI)	
Input Type	Dry Contact
Input Resistance	4kΩ
Pulse Frequency (Max)	100Hz, 50% Duty Ratio
SOE Resolution	2ms

OPERATING ENVIRONMENT	
Operation Temperature	-25°C to 70°C
Storage Temperature	-40°C to 85°C
Relative Humidity	5% to 95% non-condensing
Pollution Degree	2

DIGITAL OUTPUT OPTION	
Digital Output (DO)	(Photo-MOS)
Voltage Range	0~250Vac/dc
Load Current	100mA (Max)
Output Frequency (Max)	25Hz, 50% Duty Ratio
Isolation Voltage	2500V

COMMUNICATION	
RS-485 (Optional)	
Modbus®-RTU Protocol	
2-wire connection, Half-duplex, Isolated	
1200 to 38400 baud rate	
Second RS485 (Optional for Acuvim-CL and EL model)	

PROFI-BUS (Optional)	
PROFIBUS-DP/V0 Protocol	
Work as PROFIBUS slave, baud rate adaptive, up to 12M	
Typical input bytes: 32, typical output bytes: 32	
PROFIBUS standard according to EN 50170 vol.2	

Ethernet RJ45	
Protocol: Modbus-TCP/IP, DNP3.0 over IP V2, BACnet-IP, SNMP V3,	
HTTP/HTTps post, FTP post, SMTP, NTP, HTTPs webserver;	
4GB Datalogging memory	

CONTROL POWER	
Universal	AC or DC
AC/DC Control Power	
Operating Range	100~415Vac, 50/60Hz, 100~300Vdc
Burden	3W
Withstand	3250Vac, 50/60Hz for 1 minute

Low Voltage DC Control Power (Optional)	
Operating Range	20~60Vdc
Burden	3W

STANDARD COMPLIANCE	
Measurement Standard	IEC 62053-22 Class 0.5S, 62053-23 Class 2
Environmental Standard	IEC 60068-2
Safety Standard	IEC 61010-1, UL 61010-1, IEC 61557-12
EMC Standard	IEC61000-4-2/3/4/5/6/8/11, CISPR 22, IEC 61000-3-2, IEC 61000-6-2/4
Outlines Standard	DIN 43700/ANSI C39.1

DIMENSIONS

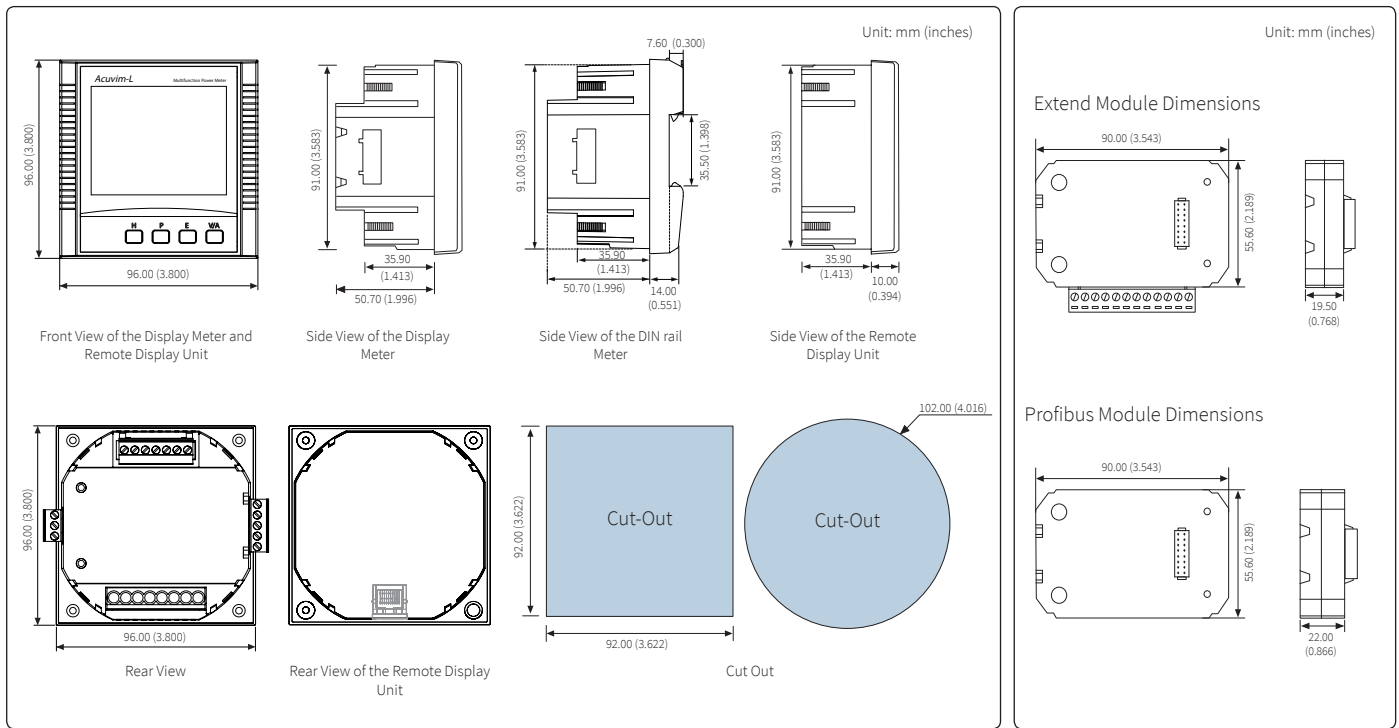

Note: 1. The cable length connecting the Remote Display Unit and the DIN Rail Meter is 2 metres (6 feet). Contact your customer service rep if you require a longer cable.
 2. The Remote Display Unit and Display Meter have the same cutout.

AXM-DIN RAIL MOUNTING ADAPTER

AXM-DIN Rail adapter provide easy installation of panel-mount Acuvim-L series meters on DIN rail in all models and IO options.

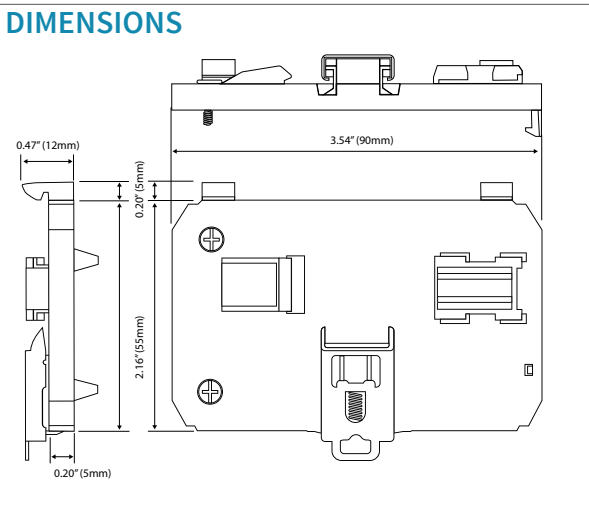

ORDERING INFORMATION

	Model	Mounting Option	Current Input	Power Supply
Ordering Number	-	-	-	-
Ordering Example	Acuvim CL	D	5A	P1V3
	Acuvim-BL	D: Standard with LCD Display	5A – 5A/1A Input field selectable	P1V3: 100~415Vac, 50~60Hz 100~300Vdc
	Acuvim-CL	M: DIN rail mount (optional Remote Display to be added)	RCT – AcuCT-Flex Input	P2V3: 20~60Vdc
	Acuvim-EL		333 – 333mV Input	

Expansion Module:

L-WEB — Protocol: Modbus-TCP/IP, DNP 3.0 Over IP V2, BACnet-IP, SNMP V3, HTTP/HTTPS post, FTP post, SMTP, NTP, HTTPs webserver; 4GB Datalogging memory

L  —

- X1: 4DI+2DO
- X2: 4DI+2DO+Second RS485
- X3: Profibus
- X4: 4DI+2DO+Profibus
- X5: 4DI+2RO
- X6: 4DI+2RO+Second RS485

Remote Display Option:

REM-DS1V3 — Compatible with Acuvim-L Series “M” (DIN Mount) models only

DIN Rail Mounting Adapter Option:

AXM-DIN — Compatible with Acuvim-L “D” (Panel mount) models only

Note: 1. Using Rope-CT as current transformer, not support the **I4, WIRING CHECK, POWER QUALITY, SEQUENCE, PHASE ANGLES** and **POWER QUALITY EVENT LOGGING** function.



Accuenergy Corporation

Los Angeles -Toronto-Beijing

North America Toll Free: 1-877-721-8908

Web: www.accuenergy.com

Email: marketing@accuenergy.com

